

**AUTOMATED GATE SYSTEM USING**

**RFID TECHNOLOGY**

**By**

**OYEDEMI KINGDAVID**

**18010301059**

**BEING A PROJECT SUBMITTED IN THE DEPARTMENT OF COMPUTER  
SCIENCE AND MATHEMATICS, COLLEGE OF BASIC AND APPLIED SCIENCES  
IN PARTIAL FULFILLMENT OF THE REQUIREMENTS FOR THE AWARD OF  
THE DEGREE OF BACHELOR OF SCIENCE**

**AUGUST, 2021**



## **DECLARATION**

I hereby declare that this project has been written by me and is a record of my own research work. It has not been presented in any previous application for a higher degree of this or any other University. All citations and sources of information are clearly acknowledged by means of reference.

---

**OYEDEMI, KINGDAVID**

---

**Date**

## CERTIFICATION

This is to certify that the content of this project entitled '**DESIGN AND IMPLEMENTATION OF AN AUTOMATED GATE SYSTEM USING RFID TECHNOLOGY**' was prepared and submitted by **OYEDEMI KINGDAVID** in partial fulfilment of the requirement for the degree of **BACHELOR OF SCIENCE IN COMPUTER SCIENCE**. The original research work was carried out by me under supervision and is hereby accepted.

\_\_\_\_\_ (Signature and Date)

Dr. F.A Kasali

Supervisor

\_\_\_\_\_ (Signature and Date)

Dr. M.O. Adewole

Coordinator, Department of Computer Science and Mathematics

## **DEDICATION**

This project is dedicated to God, who has always been faithful, kind, and compassionate to me, and who kept me alive so that I could finish it. Also, I dedicate this piece to my parents, Dr. John Oyedemi, and my mother, Mrs. Bibitola Oyedemi. They encouraged, supported, and prayed for me, and their belief in me fueled my artistic inspiration. My supervisor, Dr. Funmilayo Kasali, my lecturers, Mr. I.O. Ebo, and Mr. Festus, have all been instrumental in shaping this research, and they have had a huge effect on me in the process.

## **ACKNOWLEDGEMENT**

To me, giving thanks is a humbling experience, therefore I give heartfelt appreciation to the God who created everything, since if it were not for Him, I would simply be nothing. I am forever grateful to God for his constancy, grace, mercy, and favour toward me.

I would also want to acknowledge everyone at Mountain Top University who has had a significant effect on my life on a personal and intellectual level. I want to thank Dr. D.K. Olukoya, the university's chancellor, and every member of the university's senate and scholarship board. I would want to specifically appreciate Dr. Funmilayo Kasali, my supervisor, for believing in me and encouraging me. While acknowledging many others, including Prof. I.O Akinyemi, Dr. M.O. Adewole, Mr. Jeremiah Balogun, and Mr. I.O Ebo, I also have to acknowledge a host of other lecturers whose assistance has helped make my academic pursuits more successful.

I would also want to thank my course mates and friends who provided inspiration and encouragement during this endeavour. Thank you, God bless you.

## TABLE OF CONTENTS

DECLARATION .....	i
CERTIFICATION .....	ii
DEDICATION .....	iii
ACKNOWLEDGEMENT .....	iv
LIST OF FIGURES .....	viii
ABSTRACT.....	x
CHAPTER ONE .....	1
INTRODUCTION .....	1
1.1 Background of Study .....	1
1.2 Statement of the problem .....	3
1.3 Aims and Objectives .....	4
1.4 Proposed Methodology .....	4
1.5 Scope and Limitation .....	5
1.6 Significance of Study .....	5
1.7 Definition of terms .....	6
CHAPTER TWO .....	8
LITERATURE REVIEW .....	8
2.1 Access Management .....	8
2.1.1 Types of Access Management .....	8

2.2 Automation .....	12
2.2.1 History of Automation .....	13
2.2.2 Impact of Automation in Society .....	15
2.2.3 Advantages of Automation .....	20
2.2.4 Disadvantages of Automation.....	20
2.3 RFID .....	21
2.3.1 Introduction to RFID .....	21
2.3.2 History of RFID .....	21
2.4 RFID and Automation .....	25
2.4.1 Components of a RFID System .....	25
2.4.2 Categories of RFID tags: .....	26
2.4.3 Uses of RFID .....	30
2.4.4 Application Fields of RFID .....	31
2.4.5 Benefits Of RFID.....	33
2.4.6 Limitations of RFID.....	34
2.5 Gate Automation Using RFID .....	36
2.6 Gate Automation.....	37
2.6.1 Components of An Automatic Gate.....	38
2.6.2 Types of Gate Automation.....	38
2.6.3 Advantages of Gate Automation.....	39



2.6.4 Disadvantages of Gate Automation .....	39
2.7 RFID Gate Automation with Internet of Things (IOT) .....	40
RELATED WORKS .....	41
CHAPTER THREE .....	43
REQUIREMENT ANALYSIS AND SYSTEM DESIGN .....	43
3.1 Introduction.....	43
3.2 Method of Objective .....	44
3.3 Design and Implementation of The System.....	44
3.4 Implementing the Hardware System: .....	44
3.5 Implementing the software system: .....	57
3.6 Flowchart of the System .....	60
CHAPTER FOUR.....	63
4.1 INTRODUCTION .....	63
4.2 SYSTEM IMPLEMENTATION .....	63
4.2.1 System Interfaces.....	63
CHAPTER FIVE .....	79
5.1 CONCLUSION.....	80
5.2 RECOMMENDATION .....	80
REFERENCES .....	81

## LIST OF FIGURES

Figure 2.1 Timeline of recent RFID history from 1940s through to the present day. (Landt, 2001) .....	24
Figure 2. 2 Radio frequency spectrum diagram. (CXJ RFID Factory, 2017) .....	29
Figure 3.1 General diagram of the RFID gate System .....	45
Figure 3.2 Block diagram of the RFID automated gate System .....	46
Figure 3.3 Raspberry Pi 3 Model B microcontroller (Raspberry, 2021).....	48
Figure 3.4 RC-522 RFID Reader (Engineers, 2021).....	50
Figure 3.5 MG90S Servo Motor Image (Datasheetpdf, 2014) .....	52
Figure 3.6 R305 Fingerprint Scanner (ElectroPeak, 2021).....	54
Figure 3.7 Volt Power Supply (Raspberry, 2021).....	56
Figure 3.8 Python coding environment .....	58
Figure 3.9 Microsoft SQL Dashboard (Microsoft, 2021) .....	59
Figure 3.10 Flow chart of overall system action.....	61
Figure 3.11 Flowchart of software backend.....	62
Figure 4.1 Raspberry Pi desktop environment .....	64
Figure 4.2 Raspberry pi configuration interface .....	65
Figure 4.3 Raspberry pi terminal interface.....	66
Figure 4.4 Thonny Python Integrated Developer Environment (IDE) code writing .....	67
Figure 4.5 Python script for gate system.....	68
Figure 4.6 Python script for gate system.....	69
Figure 4.7 Python code for gate system .....	70
Figure 4.8 Breadboard view of Automated Gate System Using RFID.....	71
Figure 4.9 Schematic Diagram of Automated Gate System Using RFID.....	72
Figure 4.10 Unauthenticated RFID tag being denied access .....	73
Figure 4.11 Code Result of an invalid RFID tag.....	74

Figure 4.12 Authenticated RFID tag granted access.....	75
Figure 4.13 Code result of a valid RFID tag.....	76
Figure 4.14 Image of full system implementation .....	77
Figure 4.15 Image of full system implementation .....	78

## **ABSTRACT**

The aim of this project is to design, plan and implement a working model of a gate with valid authentication mechanism to access a building, achieved by understanding how RFID works, the components required for the project and how it relates to the problem and creating a security framework with a gate utilizing RFID system that can influence, validate, and authorize the client and open the gate for secure access.

In conclusion, this study designed and implemented an automated gate system that solves the challenges of traditional methods and enforcing security. Future works in this area be done to integrate into schools, businesses, organisations and all places requiring access to sensitive information, biometric authentication can be used to improve security where needed, renewable sources of energy can supplement power in the case of an outage.

Also, this system can be merged with machine learning algorithms for vehicle identification via license plate. Also, this system can be merged with machine learning algorithms for vehicle

identification via license plate.

## **CHAPTER ONE**

### **INTRODUCTION**

#### **1.1 Background of Study**

Radio Frequency Identification Devices (RFID) are devices to identify radio waves.

(Meghdadi, 2020). Radio Frequency Identification is a technology that has roots as far as World War II. At the time, radar was effective but identifying returning planes was a problem. German plane pilots discovered radio signal reflected would change if the planes rolled on their backs, it worked and served its purpose. It is the first passive RFID system.

RFID, is a central and cheap innovation that empowers remote information transmission. This innovation has not been all the time utilized as a part of industry because of absence of institutionalization among the assembling organizations prior.

(Asha, 2018)

Residences, organizations, corporations, military bases, etc. are places needing constant access by individuals i.e., members and non-members alike. These places may also serve as a repository for various confidential data that can be controlled and restricted to only authorized members of the respective authority, so they must be well secured. RFID automated systems like an automated gate accurately saves time by allowing already verified people gain immediate access and ease of movement.

In Mountain Top University (MTU), for example, a security officer is stationed at a gate throughout the day, whose responsibility is to verify every vehicle and person wanting to gain entry or exit the university premises. To solve this problem, a RFID tag reader, RFID tag, microcontroller is used, RFID tags are installed in the vehicles of all authorized personnel in organization and authorized personnel without vehicles. When these vehicles or individual approach the gate, the RFID tag is activated, recognized by the reader and accessed through the microcontroller which sends a signal to the gate servo and the gate is opened automatically. A webpage for management of the system collects information from the tag reader and updates the webpage with logs which can be generated through reports.

This project focuses on an RFID-enabled unmanned gate security system, RFID automated gates are not something we see much of, especially in residential areas and most schools. For this project, I present a fully automated gate that can be controlled and accessed anywhere. RFID works on this basic concept: A signal is sent to a transponder, which wakes up and either reflects back a signal (passive system) or broadcasts a signal (active system). An RFID tag is a small electronic device consisting of a small chip and an antenna. RFID generates a distinguishing feature that is unique and can be distinguished from others. RFID can be read by readers, just like a barcode or a magnetic stripe, and information can be received or modified through them.

## 1.2 Statement of the problem

Today, people are confronted with more security issues all over the world; security is now the most important issue everywhere on the planet; as a result, security of everything is becoming increasingly important as of late. Obtaining entry into buildings through gates has mostly been done manually. With the various gate security frameworks that are critical in fields like home, organization, business, and vehicle security where the likely risks of invasion are increasing day by day. Previous research has been done on various entryway bolt security frameworks, for example, conventional security frameworks that give signs utilizing caution.

A security officer may be there to validate entry and this sometimes can be time consuming, the vehicle may need to be searched, persons examined and deemed fit of entry as the case may be. Heads of security can't actually obtain a concise report on who came and who left, accurate reports can't be generated. Existing gates include tandem gates, cantilever gates, slide gates, swing gates, barrier gates, and others.

Apart from these, there are hydraulic gates and other types that are commonly used. They are mostly operated by hand. Later came automated systems that used microcontrollers and RFID to open when a vehicle with a known tag approached. However, this system consists of a microcontroller and a computer with a server which is very costly and not used often.

These problems include:

- a. **Time delay:** Depending on levels of security in an organization, the time delay of having a security officer validate and clear someone for entry is far greater than an automated system.

- b. Risk of compromise:** A security officer poses a risk of being compromised in aiding unauthorized activities against an organization.
- c. Little or no reports:** Little or no reports on who comes and leaves the organization.
- d. High cost:** High cost of server, microcontroller and server.
- e. Health issues:** Health issues of security officer.

### **1.3 Aims and Objectives**

The aim of this project work is to design, plan and implement a working model of a gate with authorization where a credible individual can gain secure access using RFID in conjunction with Internet of Things (IoT). This aim will be achieved through the following objectives:

- a. Understanding how RFID works, the components required for the project and how it relates to the problem.
- b. creating a security framework with a gate utilizing RFID system that can influence, validate, and authorize the client and open the gate for secure access.

### **1.4 Proposed Methodology**

A vehicle that needs to be authorized has an RFID tag with a unique number attached to it. When the vehicle approaches the gate, the RFID reader then reads the code and sends a signal to the microcontroller; A mini processor that serves as both a microcontroller and a



server which is replacing previously used microcontrollers, which checks for the corresponding details of the unique number and sends a message to the motor, which opens the gate if it matches the saved data in the database. The motor is programmed to open the gate for a specific time and then close it, but if the vehicle pauses in front of the gate for longer than the required time, the IR sensor reacts immediately, detecting a block in its path and keeping the gate open until the vehicle passes. The IN and OUT times of each vehicle and individual that enters the area are saved in a database sent to a webserver, allowing us to access those details from any location that uses IOT.

### **1.5 Scope and Limitation**

This project investigates how RFID technology can be used for MTU, and will only cover the design and deployment of a small-scale model of an automated gate system using RFID technology.

### **1.6 Significance of Study**

This research is being conducted primarily to address the increased need for security in Nigerian companies, businesses, schools and homes providing a solution saving cost, time and preserving life and property as the case may be. The benefits of RFID gate automation include:

**a. Saving time and money through automation:**

RFID applications automatically log, send reports, and authorize, eliminating the need for manual form filling and replacing outdated spreadsheets, as well as worker remuneration.

**b. Improving data accuracy and availability:**

RFID eliminates data duplication errors, incorrect data, and "missing data" because data is collected and uploaded electronically. The use of cloud technologies enables the organization to see the most recent data on reported entry and exit.

**c. Enhanced quality and traceability:**

Without the need for traditional manual intervention, RFID systems can ensure that individuals and vehicles have gone through the proper checks and processes.

**d. More in-depth management information:**

RFID enables real-time data capture, which provides improved management information for planning and operational purposes. These insights can be used by businesses to drive further efficiency improvements.

## **1.7 Definition of terms**

**RFID:** RFID is an acronym for “radio-frequency identification” and refers to a technology whereby digital data encoded in RFID tags or smart labels (defined below) are captured by a reader via radio waves.

**Webserver:** A web server is server software, or a system of one or more computers dedicated to running this software, that can satisfy client HTTP requests on the public World Wide Web or also on private LANs and WANs.

**IR sensor:** An infrared (IR) sensor is an electronic device that measures and detects infrared radiation in its surrounding environment.

**GSM:** The Global System for Mobile Communications (GSM) is a standard developed by the European Telecommunications Standards Institute (ETSI) to describe the protocols for second-generation (2G) digital cellular networks used by mobile devices such as mobile phones and tablets.

**Raspberry Pi:** The Raspberry Pi is a low cost, credit-card sized computer that plugs into a computer monitor or TV, and uses a standard keyboard and mouse.

## CHAPTER TWO

### LITERATURE REVIEW

#### 2.1 Access Management

Access management (AM) is the process of identifying, tracking, controlling and managing authorized or specified users' access to a system, application or any IT instance (Techopedia, 2021).

The fundamental goal of access management is to provide access only to those who are permitted within a location, including but limited to large organisations such as apartment complexes, industrial areas, and the military.

These buildings contain a wealth of secret data that may be guarded and granted access only to those with authorised access. The most important safety consideration for a company is the quality of its entrance security system, because any staff or customers who enter the industry or apartment have to pass through these entryways. This means that they must be kept an eye on.

##### 2.1.1 Types of Access Management

a. Non-automated Access Management

b. Automated Access Management

a. **Non-Automated Access:**

This refers to the traditional means of getting access into an information sensitive location which can as well be a residential area, industry, corporate environment and so on. A form of physical security used to limit or enable entry to a certain area or building is referred to as access control systems. They are most frequently installed to provide protection against vandalism, theft, and trespassing for businesses and other assets. They are especially beneficial in establishments that demand a greater level of security and protection.

**Components of non-automated access:**

- a. Security guard or personnel: Also known as a protective agent is a specially trained individual employed by a government or private party to protect the property, people, and/or equipment of the company (corporation, firm, organisation, or other type of entity) from various hazards (destruction, injury) by making frequent patrols and using other appropriate methods to deter illegal and inappropriate activities.
- b. Collapsible traffic-teeth or metal spikes: Using a directional spike system, this directional traffic system directs traffic in one direction. The car may be allowed admission or denied and if admitted, the only way to drive is in one direction, other substantial tyre damage.
- c. Identification card: An ID card verifies that the person presenting it is who they claim to be. You can utilise it to find more information, such as an application form. IDs issued by legitimate government agencies, such as state or federal, are valid. For example, drivers', military, and passport licences.
- d. Radio communication: The use of two-way radio equipment to exchange information. For security purposes, a person must contact security beforehand or they will be radioed in after their identification has been verified.

**b. Automated access:**

Using technology to strengthen security is referred to as "automated access." Automated access bridges the gap between automation that does not include the user (automated access that is not human-assisted) and automation that does involve the user (human assisted automation). The method is virtually fool proof. Although it is not enough on its own, it can be relied on to accomplish what it was built to do, the way it was built to do it, consistently, with the use of monitoring and maintenance, and used in tandem with qualified security personnel, it can be a tremendous asset to reinforcing security.

**Components of automated access:**

- a. Biometrics.
- b. Gate intercom systems.
- c. Radio Frequency Identification (RFID) access control systems.
- d. Gate keypad entry system.
- e. Vehicle detection systems.
- f. Cell phone gate access systems.
- g. Surveillance systems.
- h. Bar codes and Quick Response (QR) codes.

- a. **Biometrics:** The human body is used as a form of identification. Biometric authentication includes fingerprint scans, retina scans, and voice recognition.
- b. **Gate intercom systems:** A gate intercom system is a security solution that enables tenants to communicate with visitors and let them in remotely via the gate, a control panel and a wireless intercom system  
  
Visitors can utilise the base station to contact other renters and gain entry to the facility. Substations are the equipment that renters use to react to calls and unlock the gate remotely. Using hardware or residents' smartphones to install substations is permissible.
- c. **RFID access control systems:** RFID is commonly used in access control for doors, but the most frequently seen application is for staff entrance cards and also vehicles. In this instance, RFID-enabled badges are commonly used to identify employees, acting as a fundamental system for businesses and industries that utilise access control systems.
- d. **Gate keypad entry systems:** Easy and efficient control of entrance to property or building can be achieved using wireless keypads for electric gates. This password system offers quick access for appropriate personnel while ensuring that lost or stolen keys or key cards do not happen.
- e. **Vehicle detection systems:** Such systems have significant detection capabilities, precision, and versatility when it comes to detection kinds, such as speed, vehicle counts, vehicle classification, wrong-way vehicles, and accidents. The entire system, whether it is a subsystem like traffic flow control, or a main component like the central control room, has many subsystems.

- f. **Surveillance systems:** The systems range from simple security cameras to complicated alarm systems. Security cameras can be installed in public spaces as a deterrent. This will help to monitor the presence and logs of entry and exit.
- g. **Barcodes and QR codes:** This technology can be used to provide a method of authentication that verifies the authenticity of a source by scanning a barcode or QR code that contains a user's data.

## **2.2 Automation**

Automation: the creation and application of technologies to produce and deliver goods and services with minimal human intervention. The implementation of automation technologies, techniques and processes improve the efficiency, reliability, and/or speed of many tasks that were previously performed by humans (Techopedia, 2021)

Automation is the industrial word given to the greater use of automated devices and controls in mechanised production lines by D.S. Harder, engineering manager of Ford Motor Company in 1946. A lot of people use the phrase, but outside of manufacturing, it has a range of other systems where human effort and intellect are replaced by a substitution of mechanical, electrical, or electronic activity.

Automation began in the early part of the industrial revolution, around the year 1790 to 1840, with industrial machinery and equipment, The Analytical Engine, designed by Charles Babbage in 1837, acquired the nickname “computer”.

Automation has greatly advanced the digital age and has brought about better efficiency and output of work done. Machines, built with humanity's goal of automating chores, can



accomplish an astounding diversity of work. Our distant ancestors would have been amazed to know that semi-autonomous robots can now do chores like washing plates, cleaning, laundry and can even accomplish more impressive tasks like space travel. Automated data extraction and interpretation, as well as advanced predictive modelling, are enabled by machine learning. Over the next few years, new biotechnology, nanotechnology, quantum computing, artificial intelligence, and 3D printing technologies will enable faster advances in automation. The combination of natural language processing and artificial intelligence has given us virtual assistants and chatbots, and has allowed Artificial Intelligence (AI) to generate newspaper articles and drive our cars.

### **2.2.1 History of Automation**

The true history of automation starts far closer than Aristotle and Socrates (AI, 2021)

Prehistoric man's efforts to manage his own physical strength using human intelligence are exemplified by the first tools fashioned of stone. During the millennia, new technologies such as the wheel, lever, and pulley were developed, resulting in an increase in the power of human muscle. This advancement was the invention of machinery that was no longer dependent on human strength to work. A few waterwheels, windmills, and small steam-driven devices are all examples of these machines.

Automated timekeeping has been in use in ancient Babylon and Egypt since 1500 BCE thanks to water and shadow clocks. As early as the 4th century BCE, Egypt utilised the automation of water wheels to gather water for agricultural purposes.

Control and fail-safe systems that we use now owe a lot to different outdated automated fountains, automatic flute players, and other controls and valves that were constructed many years ago.

The widespread manufacturing of printed books began when Gutenberg's moveable type printing machine was invented in 1439.

When French mathematician Blaise Pascal developed his mechanical calculator in 1645, he paved the way for more recent breakthroughs in computing technology.

The first continuously-rotated steam engine was built by James Watt in 1776.

In 1784, the British engineer Edmund Cartwright created the power loom, which drastically reduced the amount of work needed to produce intricate fabrics.

In early 1900s, Czech playwright Karel Capek invented the term robot in his play,

Rossum's Universal Robots, describing working machines with artificial intelligence. Capek invented the term robot takeover, and his play is considered the first appearance of the concept in literature. Robots began to appear at the same time as science fiction became popular.

1939 marked a crucial moment in the history of automation, as the first physical robot, ELEKTRO, was put on exhibit at the World's Fair. He could move with human orders, light cigarettes, and inflate balloons.

The assembly line implemented by Henry Ford in 1913 revolutionised mass production.

Bell telephone company began to use automatic switchboards for telephones in 1919.

Completing the Colossus in 1943 was essential for Britain during World War II because it helped them defeat German encryption.

In the late 1970s and early 1980s, we found ourselves in the Information Age due to the significant increase in the availability of personal computers.

### **2.2.2 Impact of Automation in Society**

In recent times, people have been advocating for the benefits of automation in various fields, including labour unions, company executives, politicians, and college academics. This is perhaps the most controversial debate: people are concerned about how automation will affect jobs. While other significant effects of automation include its impact on productivity, the economy, education, and quality of life, automation has an influence on all of these issues.

Productivity: is defined as the ratio of the number of units of output produced by an organisation to the number of units of labour input. As a result of an increase in production rate and a reduction in labour content, automation boosts productivity. Over the course of time, productivity gains have allowed companies to decrease the price of items while simultaneously enhancing the standard of living for the general public.

Automation, robots, computer systems, and similar technologies have created new concerns in regards to education and training. Due to automation, there is a dearth of qualified technicians that can execute the technology proficiently. Due to the lack, automated systems are moving at a slower pace. The lack of competent personnel in automation technologies calls for a workforce development strategy to increase the number of skilled technicians. Laboratories do not always have the most recent technological equipment, which makes it difficult to train technicians in these disciplines.

While automation technology is traditionally applied in manufacturing, a great deal of progress has been made in a variety of other industries, including telecommunications, transportation, services, and consumer goods.

**In communication**, automation affects: telephone switching, local area networks, communications satellites, and automated mail-sorting machines and more

Telephone switching: Was one of the earliest practical methods mechanical switches operated manually that were remotely controlled by the telephone user via rotary dials or push buttons.

The digital computers in modern telephone switching systems are the heart of the systems. These computers monitor numerous phone lines, detect which lines need service, record the digits of each phone number as it is dialled, set up the connections, and transmit electrical signals to ring the receiver's phone.

- a. Local Area Network (LAN): Like a local telephone company, a local area network connects the computers in a single building or group of buildings. With regards to long

range and high-speed transmission of speech and digital data, local area networks are often capable of it.

- b. **Communication satellites:** For long-distance communication with greater reach and coverage than LAN's, satellite communications systems are a necessity. Without these automated guidance systems, communications such as these would not be conceivable.
- c. **Automated mail-sorting:** A mail-sorting machine that reads and sorts the envelopes according to the destination has been created for use in numerous post offices throughout the world.

**In transportation:** Self-driving vehicles, airline reservation systems, autonomous pilots in aircraft and locomotives, and urban mass-transit systems are just a few of the many possibilities that can be implemented using the tech.

Tesla vehicles have sensors to monitor the road and the environment and are additionally equipped with sensors to measure temperature, wind, tyre pressure and wheel spin. AI-generated training data directs these sensors to guide passengers to drive with confidence while not personally piloting the vehicle. All airline reservation systems enable ticket agents at widely separated locations to know if seats are available on a flight in seconds. The reservation system compares space requests with the current flight status and automatically grants space when available. Passengers will have ample early notice when their seat allocations are available.

Another implementation, called an automated pilot, is commonly found on most commercial aircraft. Under normal flight conditions, these systems use orientation sensors and various instruments to monitor and regulate the airplane's heading and orientation. Appropriate control signals are also sent to the airplane's steering gear. An instrument

landing system (ILS) uses radio signals from beacons on the ground to guide aircraft to their destination. On approach to the airport, the plane's human pilot assumes control in the event of a traffic conflict.

A modern, automated rail transportation system features such transit systems as

BART (Bay Area Rapid Transit) in San Francisco, MARTA (Metropolitan

Atlanta Rapid Transit Authority) in Atlanta, and the Metro rail in Washington, D.C. assures a safe distance between trains and controls speed, while controlling routing and adjustments to keep the system on schedule.

**In services:** The variety of automated service industries encompasses everything from health care to financial services, to governments, and retail businesses.

- a. **Healthcare:** More and more automation, such as computer systems, is being used in health care in order to boost services and alleviate the workload on medical staff. At hospitals, each nursing care floor has computer terminals that track the status of each patient, their medications, and other essential information.
- b. **Robotics:** Robotics has the potential to be employed in future healthcare delivery systems. Routine and repetitive duties are also an essential part of the job done at hospitals by nurses, orderlies, and other professionals, such as janitors. Beds, linens, and supplies can be handled more efficiently by robots since they do things like preparing beds, delivering linens, and moving goods between places in the hospital.
- c. **Banking and Finance:** Computers are a big part of automation for financial organisations, especially when handling enormous numbers of papers and financial activities. Check sorting is done using optical character recognition systems that use special alphanumeric

characters (which seem like letters in disguise) to help identify checks. Bank balances are calculated and recorded by nearly all financial organisations utilising computer systems. Electronic banking systems, including ATMs, have been implemented by most major banks. These automated tellers are conveniently located and let consumers do everyday activities, including deposits, withdrawals, and balance inquiries, without the aid of bank employees. Automated systems also conduct backend management of database and internet banking activities. Automated credit card transactions have become popular. An increasing number of restaurants, merchants, and other organisations are employing automated systems that do credit card verification and creditworthiness checks in seconds for customers who are waiting for a transaction to be finished.

Automated consumer products help the user in a wide range of ways, including tiny appliances to automobiles. Almost all modern household appliances, including microwaves, washing machines, dryers, refrigerators, and video recorders, incorporate a microprocessor that serves as the computer controller for the equipment. The consumer uses the controller to configure the appliance, such as setting the power level in irons, dryers, and timers in toasters. In this instance, the user does not think of the method as "programming a computer" because the device's programming is simply a matter of following a set of pre-programmed buttons.

Automation is found in many consumer products, and automobiles are no exception. These days, most vehicles have many microprocessors, such as fuel-air ratio management, the clock, the radio, and temperature and cruise control.

### **2.2.3 Advantages of Automation**

- a. Boost production rates and overall productivity.
- b. Automation is able to significantly cut the time it takes a human being to process and deliver on the same task.
- c. Increased process control enables greater material utilisation, reducing scrap.
- d. decreasing the amount of human error.
- e. Automated methods are less likely to introduce variations that produce inconsistent quality.
- f. Automated systems typically keep workers away from hazardous work areas, thus protecting them from the hazards.
- g. Reduction in the number of hours worked each week on average by factory workers results from automation.

### **2.2.4 Disadvantages of Automation**

- a. High capital expenditure required to invest in automation (an automated system can cost millions of dollars to design, fabricate, and install)
- b. Higher level of maintenance needed
- c. A generally lower degree of flexibility when it comes to possible products
- d. Humans will become dependent on automation.
- e. Workers may be displaced from their work, or from their geographic location.



## **2.3 RFID**

### **2.3.1 Introduction to RFID**

RFID is a form of wireless communication that incorporates the use of electromagnetic or electrostatic coupling in the radio frequency portion of the electromagnetic spectrum to uniquely identify an object, animal or person (Amsler, 2021). RFID has evolved over a long time from being a combination of radar and radio technology from World War II to recently being available in the consumer market for various applications and uses due to reduced cost and standardization in the industry.

### **2.3.2 History of RFID**

RFID-like technology was utilised for the first-time during World War II (WWII). Sir

Robert Alexander Watson-Watt devised the radar in 1935, and was employed by the

American, British, and German militaries to warn of approaching planes during World War II. However, radar signals used to identify oncoming aircraft were unable to distinguish whether the aircraft belonged to the Allies or Germany.

The Germans realized that rolling their planes as they returned to base caused the radio signal to alternate. Mirrored back, this primitive method warned ground radar operators that these were German planes, not Allied planes (this was the first passive RFID system).

RFID is based on the same principle. A signal is sent to a transponder, which responds and either reflect (passively) or transmit the signal (actively).

The first technology was the Continuous Wave radio generation which was created in 1906 by Ernst F. W. Alexanderson. The second technology was the Radar device which is thought to have been developed in 1922 and was utilised extensively in World War II (Landt, 2001).

On January 23, 1973, the first active RFID tag with rewritable memory was granted a patent in the United States. A California entrepreneur named Charles Walton was granted a patent for a passive transponder that may unlock a door without the usage of a key. Los Alamos scientists who worked on the project left in the mid-1980s to start a company that developed automated toll payment systems. These technologies are now commonplace on roads and bridges all around the world. IBM developed and patented an ultra-high frequency (UHF) RFID technology in the early 1990s. Because of the low volume of sales and the lack of open, universal standards, the technology was pricey at the time.

Access control, payment systems, and contactless smart cards all employ 13.56 MHz

RFID technology today. They are also employed in automobiles as an anti-theft system.

An application of early RFID was used to tag cattle;

The Auto-ID Centre at the Massachusetts Institute of Technology was established in 1999, thanks to financing from the Uniform Code Council, EAN International, Procter & Gamble, and Gillette.

David Brock and Sanjay Sarma, two professors at the university, have been doing research on the potential of embedding low-cost RFID tags on all manufactured goods in

order to follow them throughout the supply chain. To keep the costs reasonable, they decided to just place a serial number on the tag (a simple microchip storing little information would be less expensive to produce than a more complex chip with more memory). The data linked with the tag's serial number would be maintained in an online database. Sarma and Brock fundamentally altered people's perceptions about RFID in the supply chain. Tags used to be a mobile database that contained information about the product or container they were travelling with, by connecting items to the Internet using RFID, Sarma and Brock transformed RFID into a networking technology.

This was a significant development for businesses since it allowed a manufacturer to notify a business partner when a cargo was leaving the dock at a production plant or warehouse, and a store to notify the manufacturer when products arrived. Between 1999 and 2003, the Auto-ID Centre received assistance from over 100 major end-user firms, as well as the US Department of Defence and a number of significant RFID suppliers. In Australia, the United Kingdom, Switzerland, Japan, and China, it established research laboratories.

It created two air interface protocols (Class 1 and Class 0), the Electronic Product Code (EPC) numbering system, and a network architecture for searching the Internet for data linked with RFID tags.

In 2003, the Uniform Code Council was granted a licence to commercialise EPC technology, and EPC global was formed as a joint venture with EAN International.

In October 2003, the Auto-ID Centre closed its doors, and Auto-ID Labs took up its research duties.

Some of the world's largest merchants, including Albertsons, Metro, Target, Tesco, and Wal-Mart, as well as the United States Department of Defence, have said that they want to utilise EPC technology to track items in their supply chains, other sectors, including pharmaceuticals, tyre manufacturers, and defence, are adopting the technique as well.

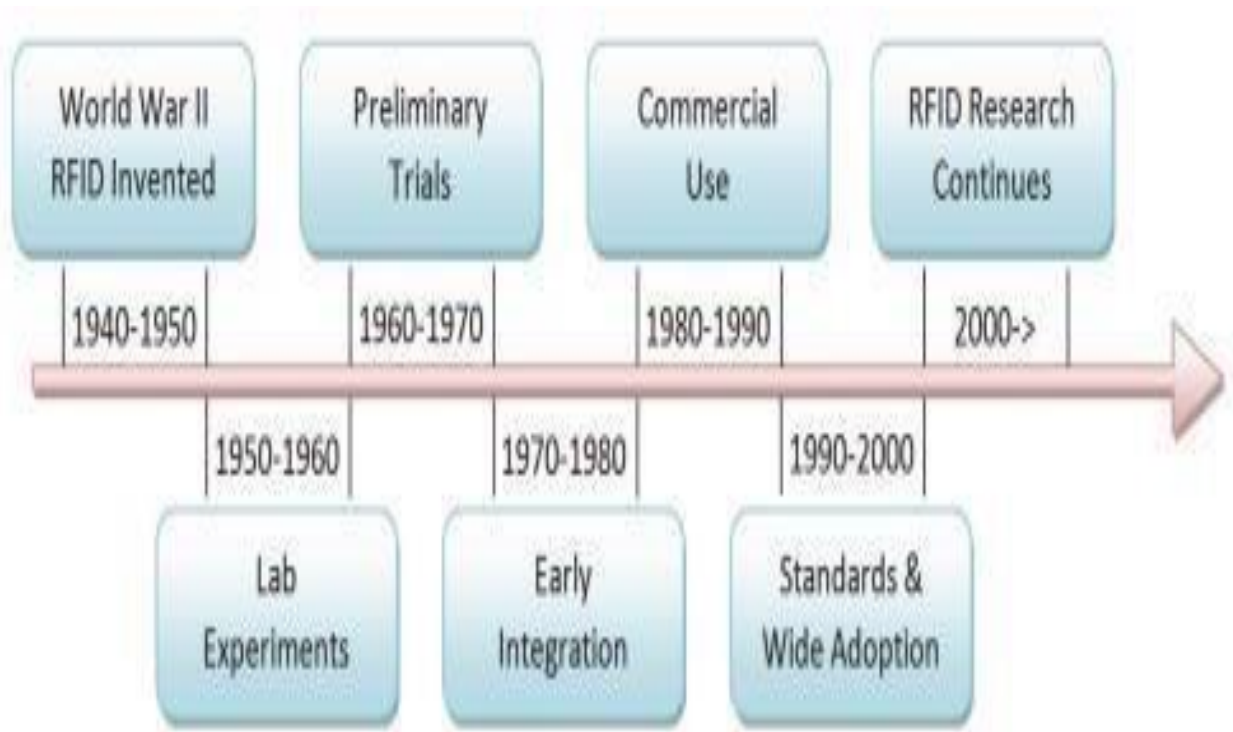

Figure 2.1 Timeline of recent RFID history from 1940s through to the present day. (Landt, 2001)

## **2.4 RFID and Automation**

RFID, according to (Want, 2006), permits identification from a distance and does so without requiring a line of sight, unlike older bar-code technology.

RFID systems include electronic devices called transponders or tags, and reader electronics to communicate with the tags. These systems communicate via radio signals that carry data either unidirectional or bidirectional. (Mandeep Kaur, 2011)

### **2.4.1 Components of a RFID System**

- a. A RFID tag, transponder or smart label
- b. RFID reader
- c. Antenna

#### **RFID tag:**

An RFID tag is accessed when a radio transmitter on the reader emits a signal that causes the transponder to communicate data to the transceiver.

An RFID tag has an integrated circuit and an antenna within a protective casing, all held together by an adhesive. For a given application, the protective material relies on the substance used. Employees, animals, products and goods can receive identification badges with RFID chips. These badges are normally manufactured from sturdy plastic, and the chip is inserted in between the layers of plastic.

RFID tags may hold a greater number of unique IDs than bar codes and can also store other information such as the manufacturer, product kind, and even environmental data like temperature. RFID tags hold data collected by an RFID reader; the data stored typically ranges from 64 bits to 1 kilobyte for passive tags and up to 128 kilobytes for active tags.

Sizes, forms, and materials of RFID tags vary. Capabilities vary depending on the frequency.

Types of tags can come in glass, rubber, plastic, metal, TPE and more.

#### **2.4.2 Categories of RFID tags:**

- a.** Active tags.
- b.** Passive tags.

##### **Active tags:**

To be effective, an active tag must have a power source, coupled with the antenna, onboard integrated chip, and encapsulation. These tags are linked to an energy infrastructure that is powered, or utilise energy that is stored in an integrated battery. The RFID chips used in passive tags are often smaller and less capable.

An inbuilt power supply and onboard electronics are part of each active tag. A tag's lifetime is limited by the stored energy, but the number of read operations the device has to endure must also be taken into consideration.

A battery or solar power supply is used most of the time, yet occasionally a power supply will be a battery. In contrast to passive tags, the built-in power supply is capable of powering the tag and communicating data without relying on the reader to supply power. Passive tags are able to be read from a maximum of 20 feet away, whereas active tags may be read from 100 feet away.

Most Integrated hardware, such as sensors, microprocessors, and input/output ports, all of which are powered by the tag's onboard power source, are commonly known as sensors, microprocessors, and input/output ports, respectively. Active RFID tags can be employed in more types of applications than passive RFID tags due to electronics.

perishable food items may be given sensors that would collect data and use it to tell the user when food may spoil. Expiration dates may only be a good guideline if the product is stored under optimal conditions as temperature, humidity, and light exposure). Therefore, if the goods are not stored properly, the printed date could expire before the product has actually expired. The RFID tag with a temperature sensor might be able to ascertain if a meat pack is expired.

Sensors could be affixed to vehicles that have a lot of moving parts, like an automobile, to gather information such as how frequently the vehicle's wheels turn, whether the vehicle's tyres are under pressure, how close the vehicle is to objects like other vehicles and stationary objects, the vehicle's temperature, and the vehicle's cruise control.

The transponder affixed to an aeroplane that identifies its national origin is an example of an active tag. A second example is EZ Pass tags affixed to a vehicle.

Active RFID frequency ranges from sub 1 Giga Hertz (GHz) to 2.4 Giga Hertz (GHz).

Sub 1 GHz is used by Proprietary, Dash 7, SimpliTI.

2.4 GHz is used by technologies such as ZigBee, Bluetooth, Wi-Fi.

**Passive tags:**

These tags are comprised of three elements: the antenna, integrated chip, and encapsulation.

The RFID chip is used to store data, as well as carry out certain functions. The chip may be read-only (RO), write-once, read-many (WORM), or read-write, according on its design (RW). Typically, passive RFID chips can store between 2 and 1000 bits of information

The antenna is used to "absorb" radio waves sent by the reader, and to "transmit" and "receive" data. Large antenna size greatly influences passive RFID tag performance: more energy is collected and sent back out with larger antennas. As antennas get larger, they allow for a wider range of readability (although not as high as those of active tags).

The antenna design is just as critical to the tag's performance. Most Low frequency (LF) and High frequency (HF) antennas use coils since they are mostly magnetic in nature. The alternative option, though, is to utilise an ultrahigh-frequency (UHF) antenna that is a lot like an old-fashioned TV antenna, sometimes known as a rabbit ear antenna.

Mylar or plastic film are widely used as the encapsulating component of a passive RFID tag. Attached to the material, which may be considered the "glue" that binds all of the tag's components, is the antenna as well as the chip.



Passive RFID frequency ranges from 100 Kilo-Hertz (kHz) to 13 Mega Hertz (MHz)

LF ranges from 120-148 kHz

HF works at 13 MHz

Passive RFID tags are usually smaller and less expensive than active ones.

Passive RFID tags require no batteries or maintenance. It is possible to incorporate an indefinite operating life and the compactness required for a practical sticky label into the tags. A tag reader must turn on and connect to a tag, which is then in turn powered and communicated with. In order to capture the energy and transfer the tag's ID, the tag antenna collects the energy and transmits the tag's ID. Encapsulation protects the tag and antenna from various environmental conditions and keeps the tag's integrity intact.

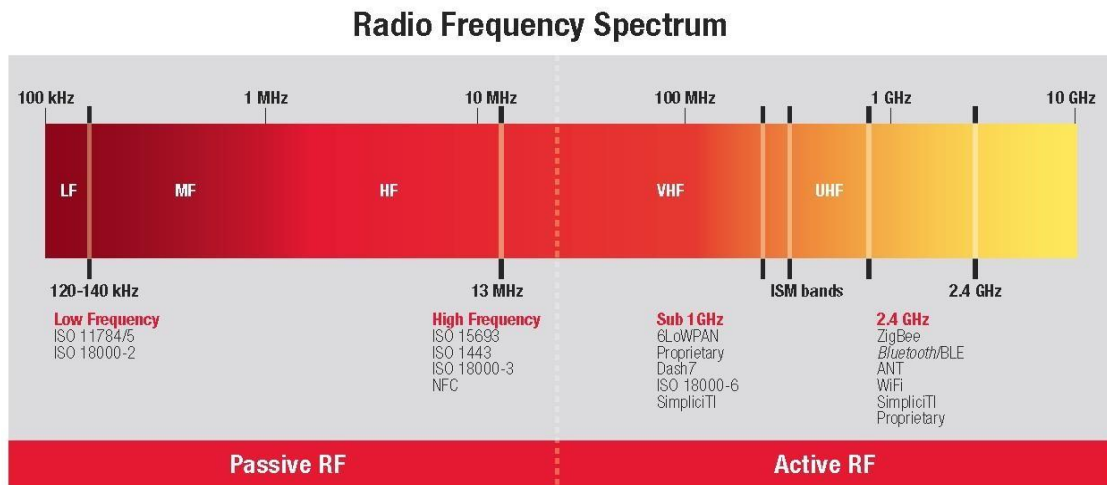

Figure 2.2 Radio frequency spectrum diagram. (CXJ RFID Factory, 2017)

### 2.4.3 Uses of RFID

- a. Instance or class identification: Unless you have a specific requirement for type or instance information, an RFID database will generally be used in the background to supply or request the extra information.
- b. Asset tracking: One can track the current location of a uniquely identifiable item, such as a specific reader, if a reader has been designated to a known location. Integration of RFID-based features has been adopted by several logistics firms and postal services, such as UPS, FedEx, USPS, and Finland Post.
- c. Manufacturing Process: The use of RFID in manufacturing plants has been commonplace for more than a decade. Tracking part usage and work in process as well as reducing defects, increasing productivity, and manufacturing different versions of the same product are some of the functions of a usage/work-in-process/defects management system.
- d. Retailing: Many retail establishments, including Best Buy, Metro, Target, Tesco, and Wal-Mart, are leading the charge for RFID implementation. Until these retailers improve supply chain efficiency and keep inventory on the shelf when customers want to buy, these retailers will remain uninvolved with improving supply chain efficiency.
- e. Payment systems: RFID is a hot technology in the supply chain, but it is also starting to be used in commerce as a convenient form of payment. Radiofrequency identification (RFID) is an increasingly popular option for motorists, who use it to pay for tolls without having to stop. Customers are using active RFID tags to pay for their food at drive through windows.

## **2.4.4 Application Fields of RFID**

### **a. Asset Identification:**

Searching for and tracking stationary or in-motion assets, like goods and services, healthcare facilities, wheelchairs, and patient personal effects, was much more difficult than locating laptops, servers, and equipment inside a corporation, or within a data centre. Active RFID technology makes it possible for users to instantly determine the general location of tagged assets anywhere within a facility.

### **b. personnel tracking:**

There are indeed a lot of asset tracking systems in use, but not many people tracking systems. Hospitals, schools and prisons require tracking places.

Radio Frequency Identification Tags (RFID) are used by the hospital to keep track of their high-risk patients. When an emergency occurs, equipment vital to patient and medical care can be tracked. Doctors can use it in mental health hospitals to track their patients' activities. Due to their utilisation in the medical field, hospitals have made use of RFID tags for locating and tracking all the activities of newly born babies.

Students who are enrolled in school during official school hours can have their locations tracked, which provides a safer environment as well as a system that alerts and responds quickly.

A simple inmate tracking system. Many US states' jails are already using RFID tracking systems to keep tabs on their inmate populations.

**c. Gate Automation:**

The use of RFID technology to track cars and individuals and to produce data on them enables more secure and efficient entry frameworks in enterprises, organizations, industries, and residential areas.

**d. Document Tracking:**

This is the most frequently encountered problem. Because a large amount of data and documents are now available, it is increasingly difficult to manage a document management system. With RFID document-tracking, lost document searches and legal and financial implications of document loss are substantially reduced.

**e. Logistics & Supply Chain Visibility:**

One of the most important things to achieve in the supply chain is to increase efficiency, cut down on errors, and ensure quality. Manufacturing, shipping, and distribution systems are extremely chaotic, and in such a setting, real-time data on the status of individual goods delivers valuable insights that turn into effective actions.

**f. Race Timing:**

People utilising RFID during races, marathons, and races are one of the most common uses of the technology, but they frequently fail to know that they are being timed, and that

is due to RFID's ability to deliver a seamless experience for consumers. have a look at our DIY guide for information on RFID race timing.

**g. Library Systems:**

An RFID library solution helps circulation operations be more efficient. The barcode requires a line of sight, so checkout and check-in can take longer. However, an RFID tag can be read from multiple angles, which speeds up the process. Taking inventory of books on the shelf is faster, too.

**h. RTLS (Real Time Location System):**

Tracking assets, employees, or customers in real time is sometimes required. An RFID system provides visibility to any number of locations, including measuring the efficiency of worker movements, the effectiveness of a store floor plan, and tracking the location of valuable resources.

**2.4.5 Benefits Of RFID**

- a. tags can feature memory that enables reading and writing, while barcodes do not.
- b. As well as a unique identity, an RFID tag is capable of storing vast amounts of data.
- c. RFID tag design is adaptable to virtually any environment.
- d. It is capable of identifying elements individually rather than treating them as a group.
- e. Tags are less susceptible to bad weather (dust, chemicals, physical damage etc.).
- f. A tag can have multiple sensors attached to it at the same time.

- g. Tag placement is less limited since there is no line of sight required.

#### **2.4.6 Limitations of RFID**

Despite the advantages gained from RFID technology integration, various drawbacks prevent the wide-scale adoption into the majority of the commercial sector. There are three main issues concerning the integration of the architecture. The first issue is security when using the technology as tags are prone to various physical and virtual attacks upon the system. The second concern stems from the need for privacy surrounding the data collected as the observations recorded can be used for breaches in privacy. The third issue is that the data collected among systems, in particular where passive tags are utilised, produces data characteristics that make the systems harder to use. (Peter Darcy, 2011)

Although many RFID implementations have been documented, technical, process, and security challenges must yet be resolved before the technology can be widely adopted.

Experts are already working on numerous of today's technology shortcomings. These include:

- a. **Standardization:** There is a lot of room for negotiation when it comes to the selection of communication protocols, formats, and amounts of data included in the tag because there are no established standards. When cooperating parties move beyond a closed-loop

solution, they must first decide on communication protocols, signal modulation types, data transmission speeds, data encoding, and collision handling mechanisms.

- b. Cost: The cost of tags varies by category. According to the 2003 publication "RFID Systems in the Manufacturing Supply Chain", economic use of tags would require a maximum of 25 cents per tag for high-end products and 5 cents for typical item-level tagging. The expensive cost of active or semi passive tags (at least \$1 per tag) limits their use to scanning high-value commodities over vast distances.
- c. Data loss may occur when reading multiple tags at once. Anti-collision methods can be used to avoid a collision (most of which are patent-pending). Some reading methods are currently being developed to reduce total read time and increase tag count.
- d. Intrusion Detection refers to the discovery of foreign attacks upon the system usually utilising the tags that hinder the overall integrity of the data. The following five issues are some of the most dominant with regard to RFID security (Mitrokotsa et al., 2010; Thamilarasu & Sridhar, 2008).
  - a. Eavesdropping: Using a foreign reader to record tag data.
  - b. Unauthorized Tag Cloning
  - c. Man-in-the-Middle (MIM) Attack
  - d. Unauthorized Tag Disabling
  - e. Unauthorized Tag Manipulation

- e. **Obsolete technology:** One of the main worries of organisations utilising RFID nowadays is the technology's rapid obsolescence. New protocol standards, quicker and more fault tolerant readers quickly replace their predecessors.
- f. **Privacy:** Privacy within the context of an RFID-enabled facility refers to either unknowingly releasing critical information (deriving specific knowledge or tracking meaningless data) (Langheinrich, 2009).

## **2.5 Gate Automation Using RFID**

**2.5.1 Gate:** A gate is an accessway or framework that allows or prevents access to a location or secure area depending on the level of clearance required.

### **2.5.2 Types of Gates:**

**Slide gate:** For its low cost and convenience of usage, slide gates are preferred. Located inside the fence, it glides horizontally over the gate trench. The slide gate is supported by rollers on a metal track on the bottom.

**Cantilever gate:** Similar to a slide gate, but without the ground-sliding rollers. Instead, the cantilever gate is supported by inside fence rails. That it "cantilevers" (hangs over) the gate entrance gives it its name.

**Swing gate:** Swinging gates have hinges on one side and swing open and shut like a door. Swing gates open in a straight line. Swing gates can be two-leaf or single-leaf.



Vertical lift gate: Vertical lift gates raise and lower across the gate opening. It must be raised high enough for automobiles to pass. This type of gate requires towering vertical support towers on either side of the gate opening.

vertical pivot lift gate: In and out, vertical pivot lift gates revolve. Vertical pivot lift gates require no additional support.

Bi-folding gate: Bi-folding gates consist of two gate panels hinged together. Passage is made possible by folding in these gate panels. Bi-folding gates are often located on both sides of the gate opening. Some models require a track on top or bottom of the gate.

Barrier arm gate: Vertical barrier arm gates have a barrier arm that is vertically rotated to gain access to the barrier. To keep cars in their lanes, barrier arm gates are used. They also provide little protection due to how easy it is to walk alongside, jump over, or crawl under the barrier arm gate.

## **2.6 Gate Automation**

Refers to the update of manually operated gates with an automation system that allow owners to operate the gate remotely and conveniently.

Gate automation is the process of implementing electric gates that may be opened and closed automatically by using an intercom, key fob, or any other means are referred to as automated gates. A trustworthy component of a comprehensive strategy to home and business security is an automated gate entry system. An excellent illustration of this is the

regular use of automatic gates in a parking garage to separate public sections of the garage from private staff spaces.

In conjunction with automatic gates, access control systems, intercom systems, video surveillance systems, microcontrollers.

### **2.6.1 Components of An Automatic Gate**

- a. Gate: A gate closes an opening in a wall, perimeter, or hedge. Most commercial gates are built of highly decorative iron or durable material and are meant to match the surrounding fencing.
- b. Gate operator: The gate operator moves the gate in and out. Gate operators are electrically powered and can be chain, gear, or hydraulic driven.

### **2.6.2 Types of Gate Automation**

- a. Keypads: Utilize a specialized device that opens the gate when the correct pin is used.
- b. Biometric: This requires a fingerprint, retina scan or speech recogniser in order to unlock the gate.
- c. Barcode: Uses a line of sight to scan an authenticated user to unlock.
- d. Proximity: detects a person close by and opens the door without authentication.
- e. RFID: Uses radio frequency to interrogate, validate and authorize wirelessly over the radio range wherever it is located.

### 2.6.3 Advantages of Gate Automation

- a. **Improved Security:** Improvements to security have also been made through minimising the danger of compromise for both the organisation and the security staff.
- b. **Reduced overall cost:** In the long term, the expense of gate automation is outweighed by the reduced maintenance costs instead of wages.
- c. **Limit unwanted visitors:** Because you can regulate your gate instantly, you can keep unwanted visitors from entering your property.
- d. **Space-saving:** These gates can also help you save space on your property, especially automated sliding gates that can glide behind each other, leaving more room for other things.
- e. **Visual appeal:** Electric gates can enhance the appearance of a home or organization.

### 2.6.4 Disadvantages of Gate Automation

- a. **Cost:** An investment of both money and time is required to install electric entrances. There are several costs to be considered, ranging from buying the gate to hiring a service to install it. covering the cost of the administrators.
- b. **Power failure:** System failure, or inability to access or exit premises, could result in inconveniences if there is a power outage.
- c. **Inconvenience to guests:** Your guests will always be required to schedule appointments or phone ahead in order to gain access to the premises, which will cause them difficulty.

## **2.7 RFID Gate Automation with Internet of Things (IOT)**

**2.7.1 IoT-enabled RFID gate system:** IoT uses the internet to link various gadgets that assist us in our daily lives. Using this technology in a gateway improves system security.

In big enterprises such as industries, military or defence areas, and apartments. There is a RFID reader, a tag, a Raspberry Pi (microcontroller and server), a motor, DPDT relay, and a gate. Python is also used because it is faster. A DPDT Relay is used to drive big gates with high voltage.

Internet of Things: When linked to the internet, everything is included in the term "IoT," which has come to be associated with things that speak to each other. It consists of sensors and cell phones, as well as wearables. It is possible to collect information, analyse it, and take an action that assists someone with a specific job, or to learn from a process all by linking many linked devices with automated systems. In fact, this covers a wide variety of ideas including smart mirrors, beacons, and much more. The concept is all about networks, gadgets, and data. The Internet of Things connects the devices on closed private networks that do not have access to the internet to the Internet."

All approved staff members have RFID badges that may be scanned at the entrance to allow identification and processing. He uses his own OTP as a password to open the gate.

This system's goal is to provide a control system that can be accessible through the internet of things around the world (IOT). In order to know whether any cars or drivers are driving without authorization, the owner will be able to keep tabs on all the vehicles at all times. Managers are aware of any movement in the building since they are watching for people to enter or exit the area.

## **RELATED WORKS**

A research journal (Kaur, 2011) provided an overview of the current state of radio frequency identification (RFID) technology. Aside from a brief introduction to the principles of the technology, major current and envisaged fields of application, as well as advantages, and limitations of use were discussed.

(Nandhini, 2014) Concluded that the automation of toll plaza can have the best solution over money loss at toll plaza by reducing the manpower required for collection of money and also to reduce the traffic indirectly resulting in reduction of time at the toll plaza. In this project, a technique such as Radio Frequency Identification was introduced. This technique will include the RFID tag and reader, which in coordination with each other can be used to detect the vehicle identity.

(Sighila, 2016) Reviewed the research and development work for RFID based gate automation system with the help of IOT technology. This kind of a system can provide you with a reliable gateway with good monitoring. These types of gates can be mainly used in Industrial areas, Military areas and apartments as these places need more security.

(Gyanendra, 2010) Discussed a digital security system containing a door lock system using passive RFID. A centralized system is being deployed for control and transaction operations. The door locking system functions in real time as when the user puts the tag in contact with the reader, the door opens and the check-in information is stored in the central server along with basic information of the user. We utilize RFID technology to provide solutions for secure access to a space while keeping a record of the user.

(Patil, 2013) Discussed on prototype for home/ office automation using RFID, WSN & GSM technology is successfully researched and designed. Automatic door opening and closing is implemented using RFID, GSM and ZigBee technology.

Along with automatic door control this prototype can control various devices using ZigBee technology. With the help of this prototype one can build a secure home automation system. The system is developed for controlling lights and fans so that there is minimum power consumption using the GSM SIM300 modem. The temperature monitoring system is also developed using GSM technology.

(Asha, 2018) concluded that RFID-based security and access control systems are more secure and quickly responded to as compared to other systems like biometrics. The advantage of the RFID system is contact-less and works without-line-of-sight. By using Arduino, it is that it is easy to access and works very quickly while burning the cord. It is like Plug and Play device. Users can change the function accordingly by using Arduino. It is easier to use and more accurate.

## **CHAPTER THREE**

### **REQUIREMENT ANALYSIS AND SYSTEM DESIGN**

#### **3.1 Introduction**

This chapter presents the materials that will be used to achieve the objectives stated in this study.

### **3.2 Method of Objective**

The current system, as well as the user and system requirements, were discovered through this process. To meet the system's needs and responsibilities, relevant data was gathered using the methods to be listed. To help with the design of the system, sketches were used, such as schematic drawings, circuit diagrams, and diagrams representing breadboard connections. After establishing the hardware and software requirements, the system's design was established.

### **3.3 Design and Implementation of The System**

The automated gate system should be designed and implemented as two primary systems.

The design of the hardware is a core aspect of the overall system design:

- a. Hardware system.
- b. Software system.

### **3.4 Implementing the Hardware System:**

The RFID-based automated system may be divided into two different parts. Station module and object module are one and the same. Passive RFID tag is a component of the



object module. A complete RFID system, consisting of an RFID reader, host computer system, and gate control system, is the basic unit.

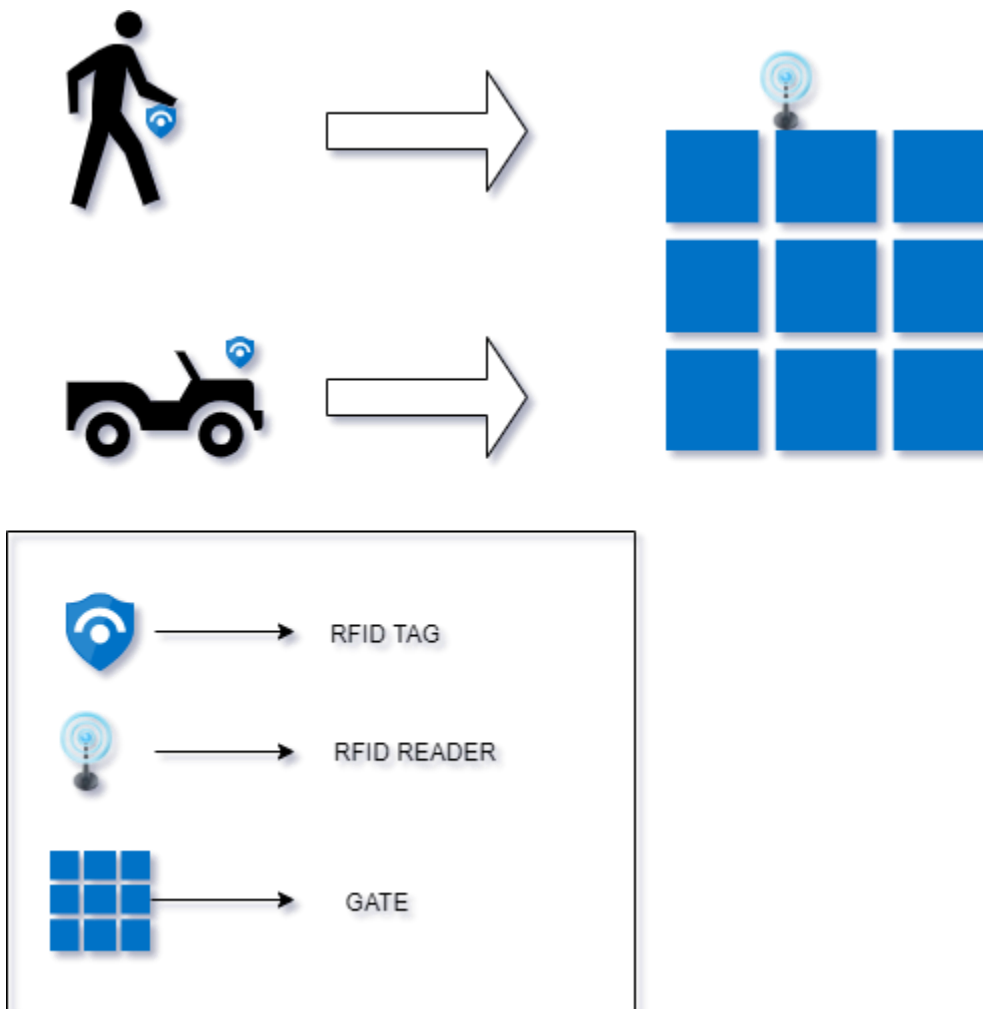

Figure 3.1 General diagram of the RFID gate System

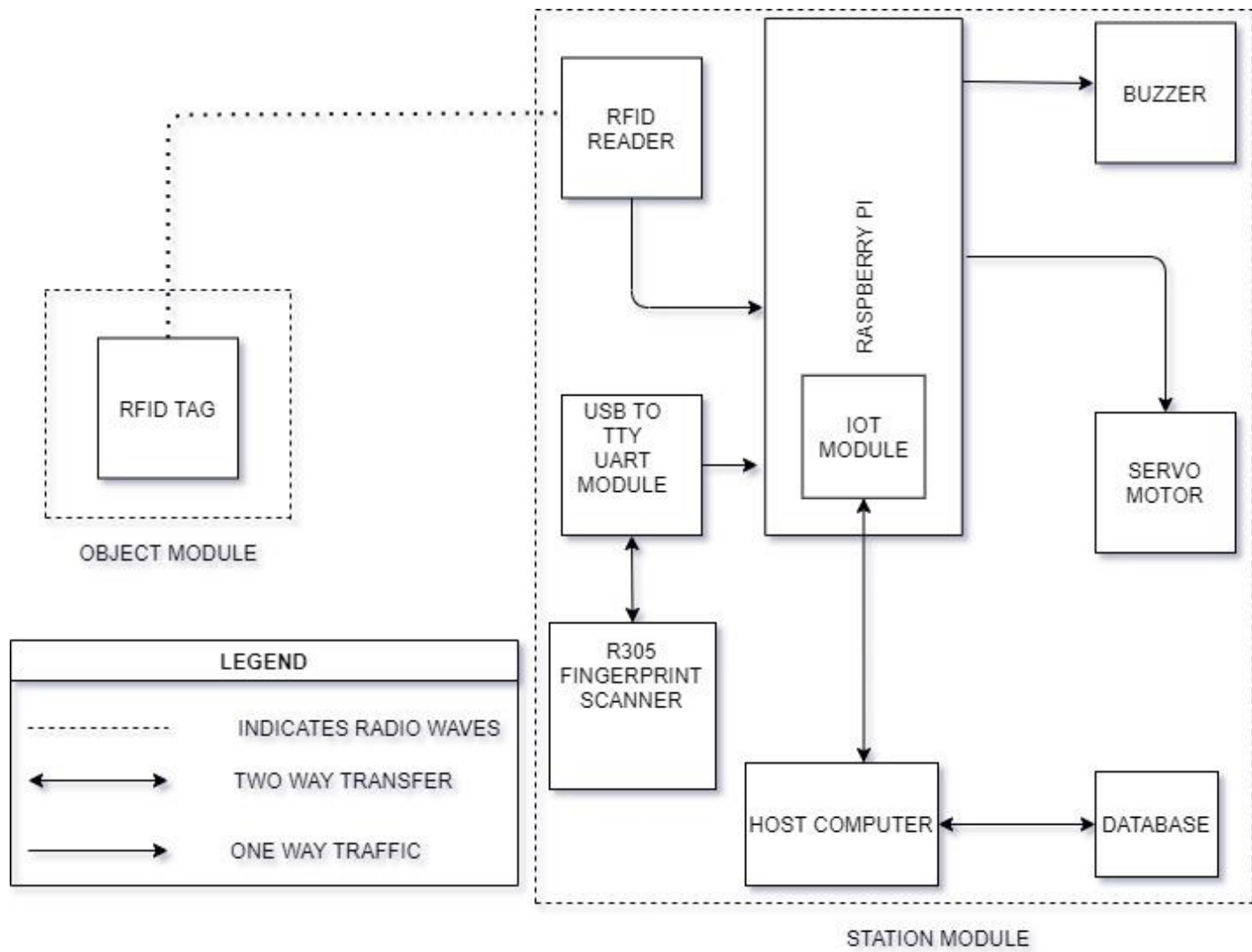

Figure 3.2 Block diagram of the RFID automated gate System

The major components of the gate control system are as follow:

- a. Raspberry Pi 3 Model A+
- b. RFID reader
- c. Servo motor
- d. R305 Fingerprint scanner
- e. Power supply unit

- a. Raspberry Pi 3 Model B:

I am employing the use of Raspberry Pi 3 Model B because it is a low-cost, mini-sized computer that has more features than other microcontrollers. It connects to a computer display or TV through a micro-USB cable, and includes a conventional keyboard and mouse. It also has a wide range of connectivity it provides which includes: A quad-core Cortex-A53 64-bit SoC with a 1.4 GHz CPU, 2.4 GHz wireless LAN which is the Internet of Things module (IoT), with 1 Gigabyte memory, Bluetooth 4.2/BLE with an Extended 40-pin GPIO connector, and a full-size HDMI. In terms of display port, you get support for Display Port, DVI-D, CVBS-4-P, and composite video port; along with

OpenGL ES 1.1, 2.0, and 3.0. Power required is 5-volt DC at 2.5 A through a micro-USB connection, 5-volt DC is available at the GPIO header.

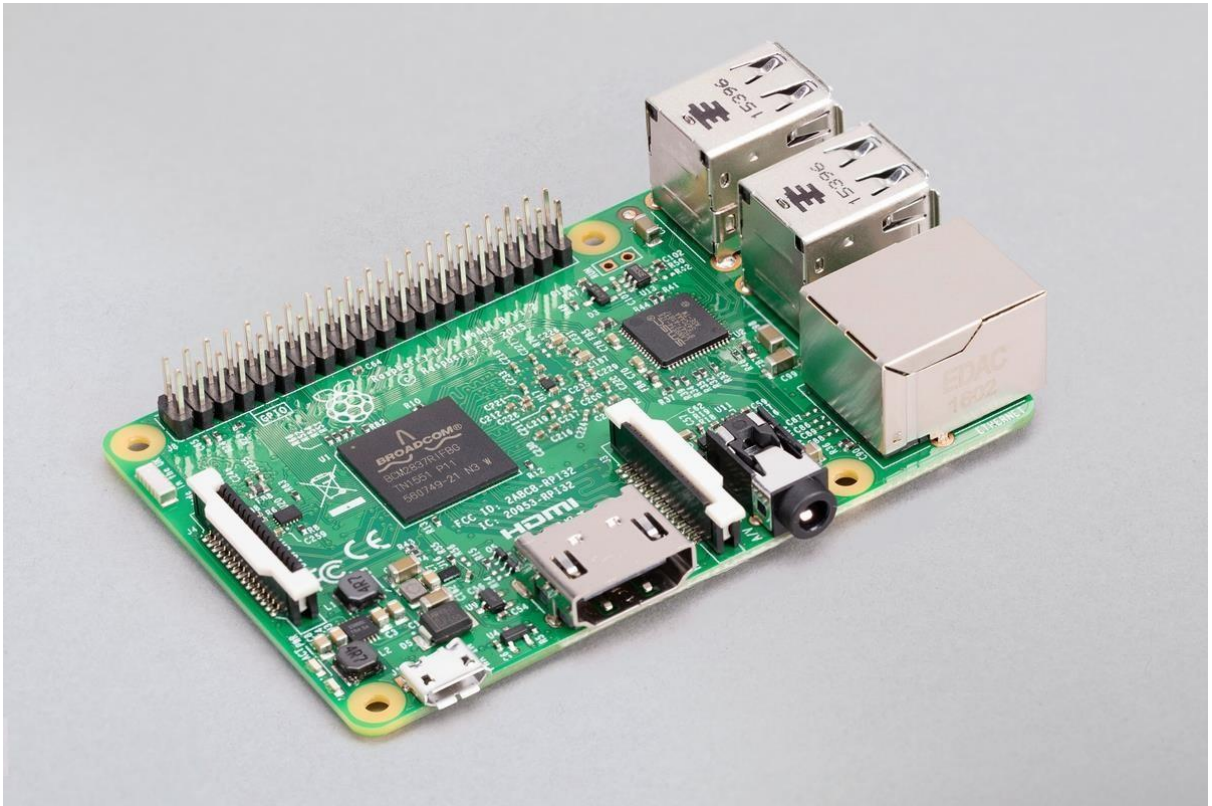

Figure 3.3 Raspberry Pi 3 Model B microcontroller (Raspberry, 2021)

b. RFID RC-522 Reader

NXP's MFRC522 IC-based RC522 RFID module. One kilobyte (KB) of memory is a standard feature on many RFID cards and key fob tags. You can use this tag to hide any type of secret message that you wish. The electromagnetic field used by this RFID reader module is made up of 13.56MHz waves (ISO 14443A standard tags). A microcontroller with a 4-pin Serial Peripheral Interface (SPI) and a maximum data rate of 10 Mbps may interact with a reader. Inter-integrated-circuit (I2C) and Universal Asynchronous Reception and Transmission (UART) protocols are also supported by the circuit. Instead of constantly pinging the RFID module, this interrupt pin helps.

Specification:

Frequency Range: 13.56 MHz industrial, scientific, and medical radio band (ISM) Band

Host Interface: SPI / I2C / UART

Operating Voltage: 2.5 V to 3.3 V

Max. Operating Current: 13-26mA

Min. Current (Power down): 10 $\mu$ A

Logic Inputs: 5V Tolerant

Read Range: 5 cm



Figure 3.4 RC-522 RFID Reader (Engineers, 2021)

c. Tower Pro micro MG90 Servo:

An electrical device called a motor transforms digital pulses into mechanical shaft movement. Servo motors' most important benefit is that they can be precisely regulated in an open loop system. motor has benefits such as:

Affordability and dependability low-torque, high-torque balance and built to function in almost any environmental condition.

For the motor, the supplied voltage is 4.8V. This motor is used in operating the gate.

Specifications:

- a. Weight: 13.4 g
- b. Dimension: 22.5 x 12 x 35.5 mm approx.
- c. Stall torque: 1.8 kgf·cm (4.8V), 2.2 kgf·cm (6 V)
- d. Operating speed: 0.1 s/60 degree (4.8 V), 0.08 s/60 degree (6 V)
- e. Operating voltage: 4.8 V - 6.0 V
- f. Dead band width: 5  $\mu$ s

**MG90S**  
Metal Gear Servo

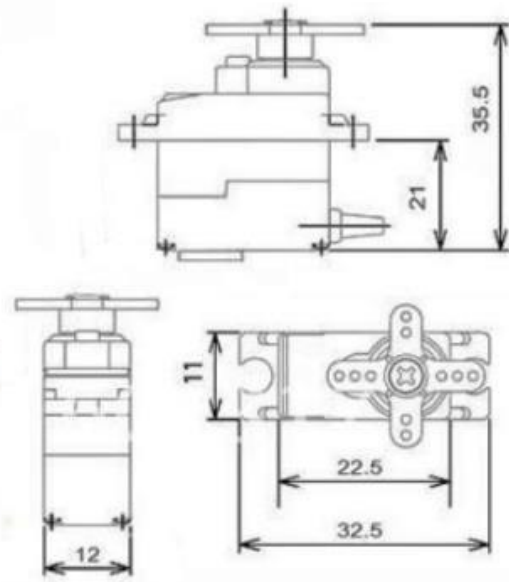

Figure 3.5 MG90S Servo Motor Image (Datasheetspdf, 2014)



- d. R305 Fingerprint Scanner: The R305 fingerprint scanner with matching method 1:1, 1:N, which can be used on a USB (Universal Serial Bus) or UART (universal asynchronous receiver-transmitter) interface. It operates 3.6v-6.0v and has a storage capacity of 256.

Specification:

Power: DC 3.6V-6.0V

Baud Rate:  $(9600 * N)$  bps,  $N=1-12$ (default  $N=6$ )

Image acquiring time:  $<0.5s$

Storage capacity: 256

Interface: UART(TTL), USB

Matching mode: 1:1 and 1: N

Security Level: 5



Photo by ElectroPeak

Figure 3.6 R305 Fingerprint Scanner (ElectroPeak, 2021)

e. Power Supply:

In contemporary electronic devices, the DC power supply unit is a crucial component since it provides a variety of DC voltages for the device's functions. The main objective of a power supply is to provide the necessary quantity of power at the correct voltage from the source. I will be using a 5V power source for the microcontroller.



Figure 3.7 Volt Power Supply (Raspberry, 2021)

### **3.5 Implementing the software system:**

The selection of software is critical in creating the system. Python and Microsoft Structured Query Language (SQL) Server 2019 used in tandem as an Integrated

Development Environment (IDE). The system is implemented in Python. The Raspberry Pi microcontroller is compatible with Python, among other programming languages.

The Python programming language is a dynamically typed, interpreted, object-oriented language with dynamic semantics. Rapid Application Development, as well as being used as a scripting or glue language to link existing components together, is a great fit for the high-level built-in data structures, as well as dynamic typing and dynamic binding. Because Python's basic, straightforward syntax is conducive to readability, this may result in lower software maintenance costs.

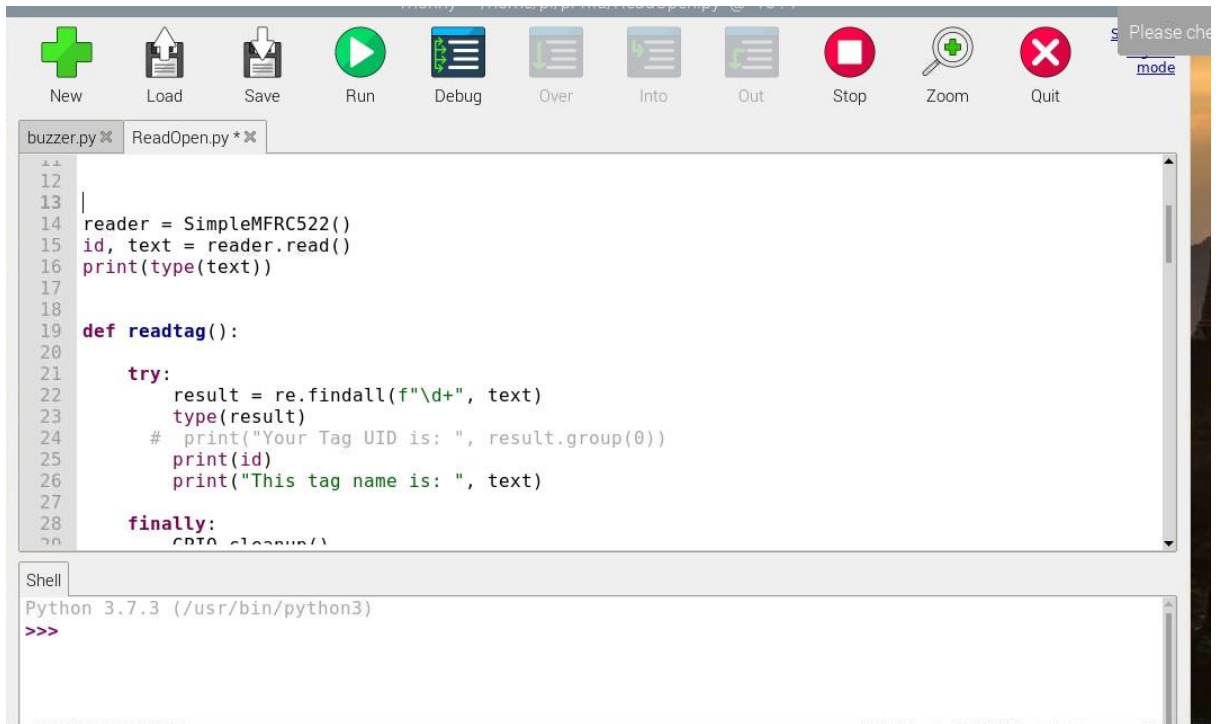

Figure 3.8 Python coding environment

# Microsoft SQL Server Performance Dashboard

Report Local Time: 3:31:04 PM

SQL2016(13.0.4422.0 - Enterprise Edition (64-bit))

**Warning:** Overall performance may be degraded because the system shows signs of being CPU-bound. This SQL Server instance is consuming the majority of the CPU. Click on any of the SQL data points in the chart below to investigate further.

### System CPU Utilization

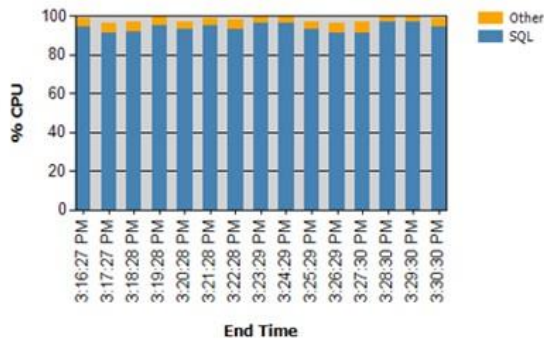

### Current Waiting Requests

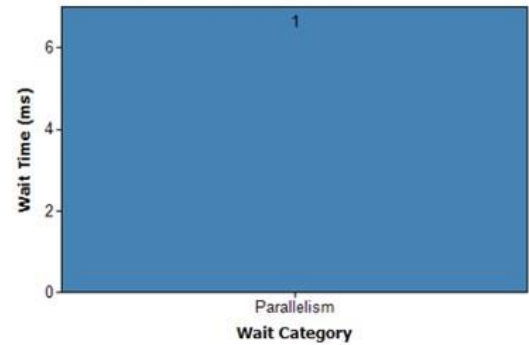

### Current Activity

	User Requests	User Sessions
Count	27	32
Elapsed Time (ms)	4573004	741818
CPU Time (ms)	2043203(44.68%)	101108(13.63%)
Wait Time (ms)	2529801(55.32%)	640710(86.37%)
Cache Hit Ratio	100.000%	98.313%

### Historical Information

<a href="#">Waits</a>	<a href="#">IO Statistics</a>
<a href="#">Latches</a>	
Expensive Queries	
<a href="#">By CPU</a>	<a href="#">By Duration</a>
<a href="#">By Logical Reads</a>	<a href="#">By Physical Reads</a>
<a href="#">By Logical Writes</a>	<a href="#">By CLR Time</a>

### Miscellaneous Information

<a href="#">Active Traces</a>	1
<a href="#">Active Xevent Sessions</a>	4
<a href="#">Databases</a>	16
<a href="#">Missing Indexes</a>	11

Figure 3.9 Microsoft SQL Dashboard (Microsoft, 2021)

Microsoft SQL Server is a relational database management system created by Microsoft. The main purpose of a database is to store and retrieve data as required by other software programmes.

### **3.6 Flowchart of the System**

The flowchart of any programme is a clear depiction of the system. Overall, the gate collecting system is shown to be this picture. RFID reader will scan the ID number from the RFID tag and, based on that number, consult the host computer database for confirmation. If the actor is registered, the gate will not open and the buzzer will sound.



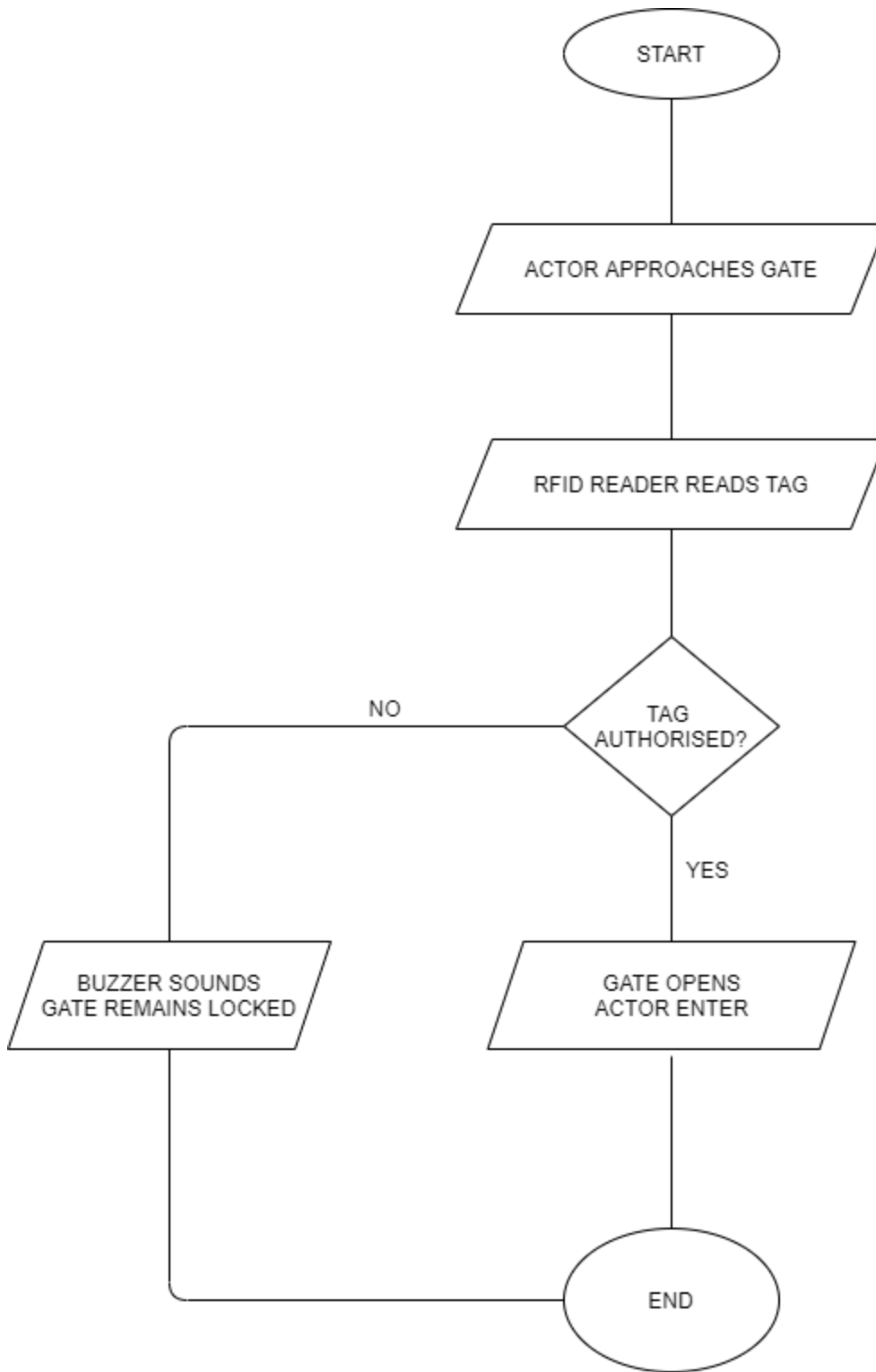

Figure 3.10 Flow chart of overall system action

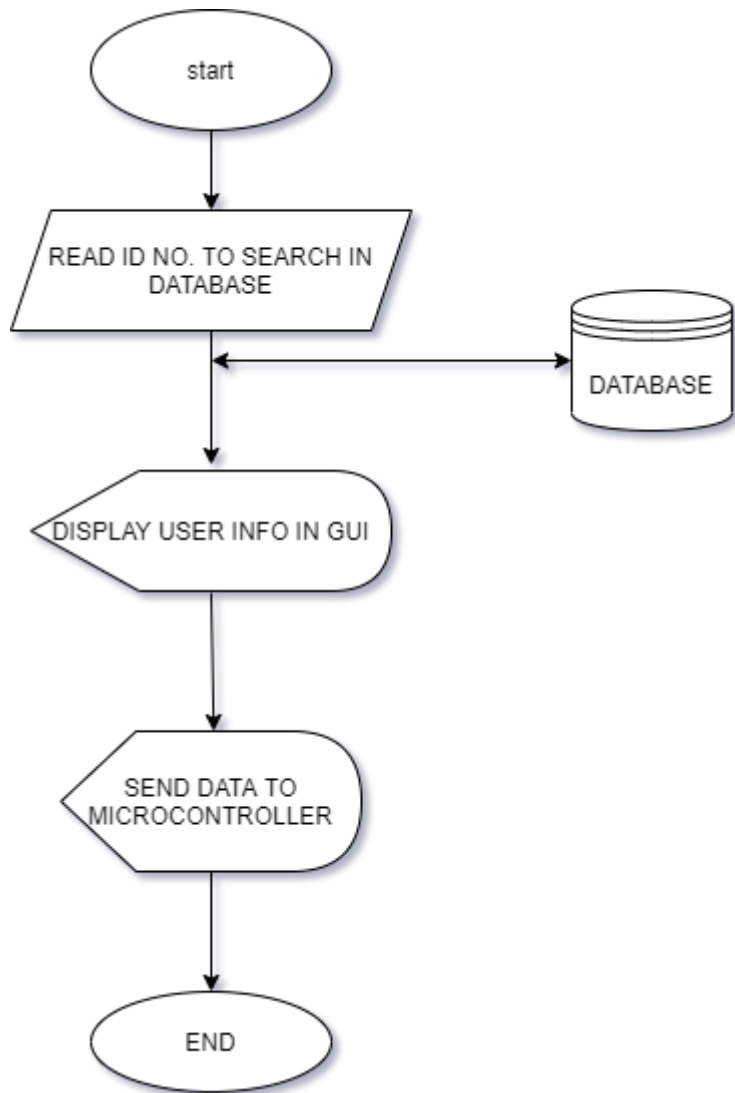

Figure 3.11 Flowchart of software backend

## **CHAPTER FOUR**

### **IMPLEMENTATION AND RESULTS**

#### **4.1 INTRODUCTION**

This chapter illustrates an RFID-enabled automated gate system's implementation specifics. The example above illustrates the necessary procedures to authenticate and validate the user. It shows multiple testing settings as well as the project testing results.

#### **4.2 SYSTEM IMPLEMENTATION**

This section describes the software, tools, and resources utilised in this area.

##### **4.2.1 System Interfaces**

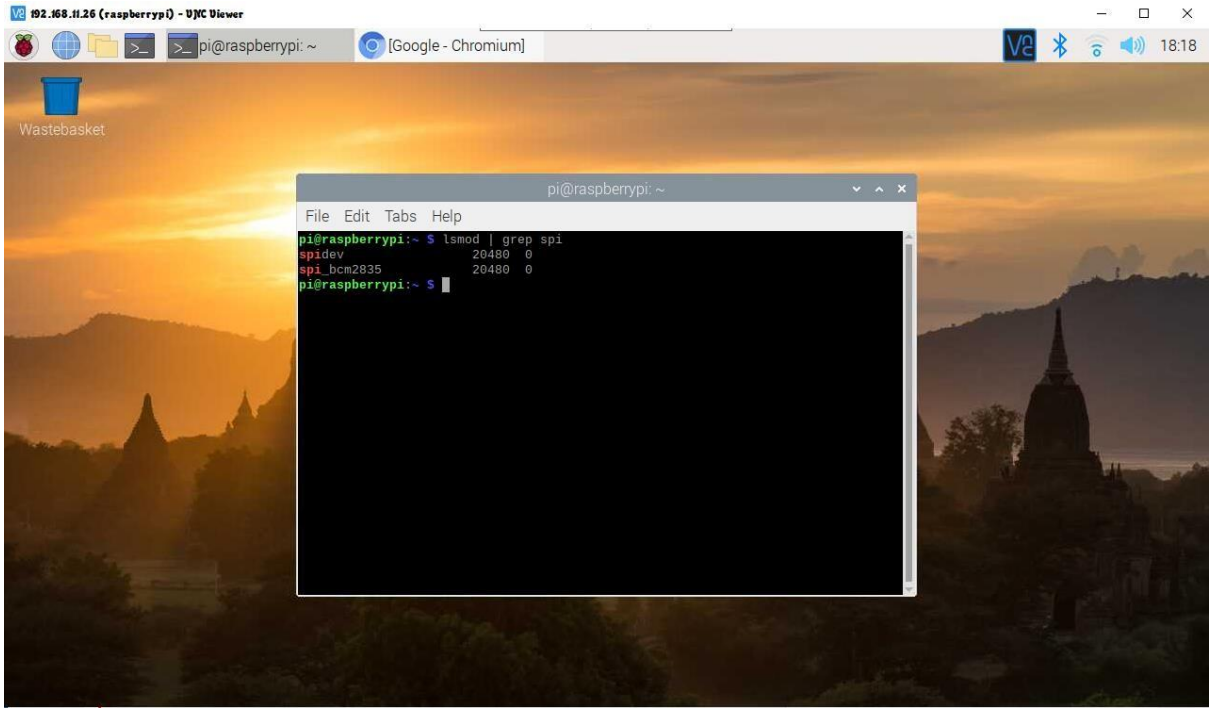

Figure 4.1 Raspberry Pi desktop environment

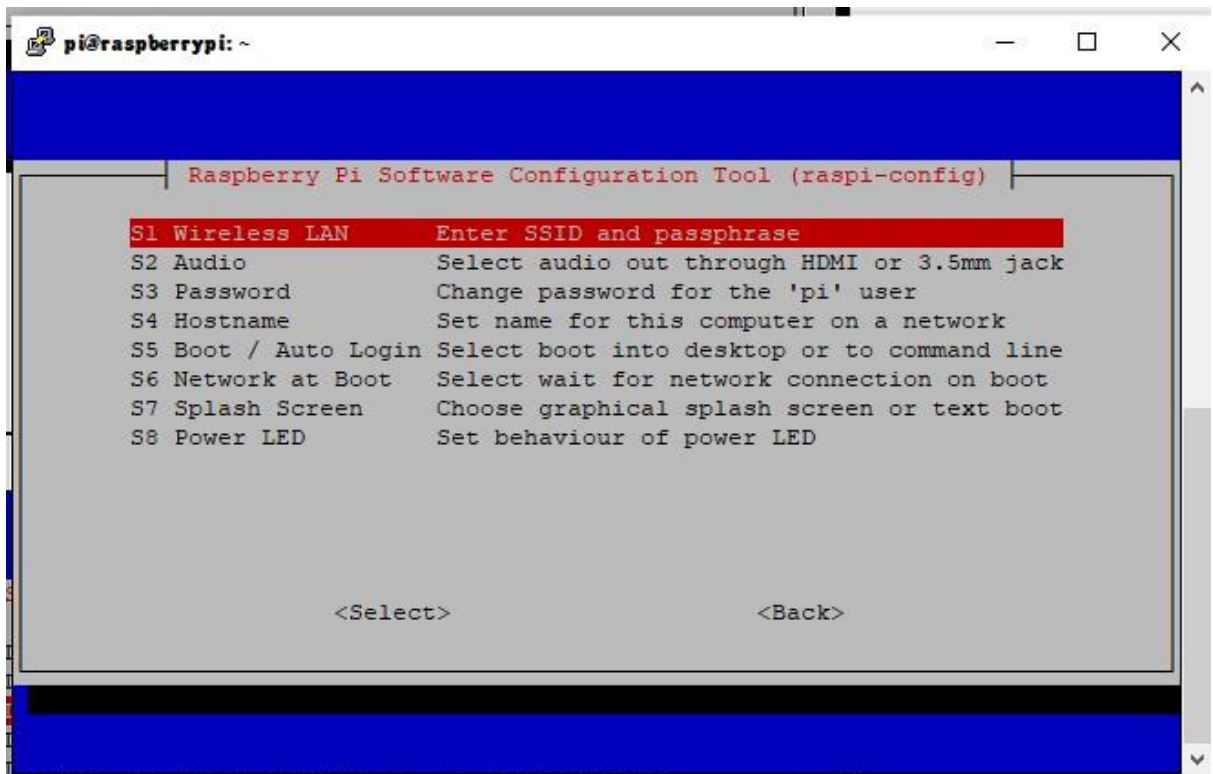

Figure 4.2 Raspberry pi configuration interface

```
169.254.2.163 (raspberrypi) - UVC Viewer
[mtulogin.net - Chrom... pi@raspberrypi: ~/pi-... pi@raspberrypi: ~
pi@raspberrypi: ~/pi-rfid
File Edit Tabs Help
archive.raspberrypi.org:80 (2a00:1098:84:1e0::1) - connect (101: Network is unreachable) Cannot initiate the connection to archi
098:88:26::1) - connect (101: Network is unreachable) Cannot initiate the connection to archive.raspberrypi.org:80 (2a00:1098:84:1e0::3) - connect (101: Net
work is unreachable) Cannot initiate the connection to archive.raspberrypi.org:80 (2a00:1098:88:26::2:1) - connect (101: Network is unreachable) Cannot initi
ate the connection to archive.raspberrypi.org:80 (2a00:1098:80:56::1:1) - connect (101: Network is unreachable) Cannot initiate the connection to archive.ras
pberrypi.org:80 (2a00:1098:84:1e0::2) - connect (101: Network is unreachable) Cannot initiate the connection to archive.raspberrypi.org:80 (2a00:1098:82:47::
1) - connect (101: Network is unreachable) [IP: 46.235.231.151 80]
E: Unable to fetch some archives, maybe run apt-get update or try with --fix-missing?
pi@raspberrypi:~$ sudo apt-get install python3-dev python3-pip
Reading package lists... Done
Building dependency tree
Reading state information... Done
python3-dev is already the newest version (3.7.3-1).
python3-dev set to manually installed.
python3-pip is already the newest version (18.1-5+rpt1).
0 upgraded, 0 newly installed, 0 to remove and 93 not upgraded.
pi@raspberrypi:~$ sudo pip3 install spidev
Looking in indexes: https://pypi.org/simple, https://www.piwheels.org/simple
Requirement already satisfied: spidev in /usr/lib/python3/dist-packages (3.4)
pi@raspberrypi:~$ sudo pip3 install mfrfc522
Looking in indexes: https://pypi.org/simple, https://www.piwheels.org/simple
Collecting mfrfc522
  Retrying (Retry(total=4, connect=None, read=None, redirect=None, status=None)) after connection broken by 'ReadTimeoutError("HTTPSConnectionPool(host='pypi.
org', port=443): Read timed out. (read timeout=15)")': /simple/mfrfc522/
  Downloading https://files.pythonhosted.org/packages/d5/b5/d33c0634cece0931c3c4e0978b0db58f248045c3b379ccf2d512b76fe044/mfrfc522-0.0.7-py3-none-any.whl
Requirement already satisfied: spidev in /usr/lib/python3/dist-packages (from mfrfc522) (3.4)
Requirement already satisfied: RPi.GPIO in /usr/lib/python3/dist-packages (from mfrfc522) (0.7.0)
Installing collected packages: mfrfc522
Successfully installed mfrfc522-0.0.7
pi@raspberrypi:~$ mkdir ~/pi-rfid
pi@raspberrypi:~$ cd ~/pi-rfid
pi@raspberrypi:~/pi-rfid$ sudo nano Write.py
pi@raspberrypi:~/pi-rfid$ sudo python3 Write.py
New data:test tag 1
Now place your tag to write
Written
pi@raspberrypi:~/pi-rfid$ cd ~/pi-rfid
pi@raspberrypi:~/pi-rfid$ sudo nano Read.py
pi@raspberrypi:~/pi-rfid$ sudo python3 Read.py
```

attendance by following our [Raspberry Pi powered RFID attendance system guide](#).

Figure 4.3 Raspberry pi terminal interface

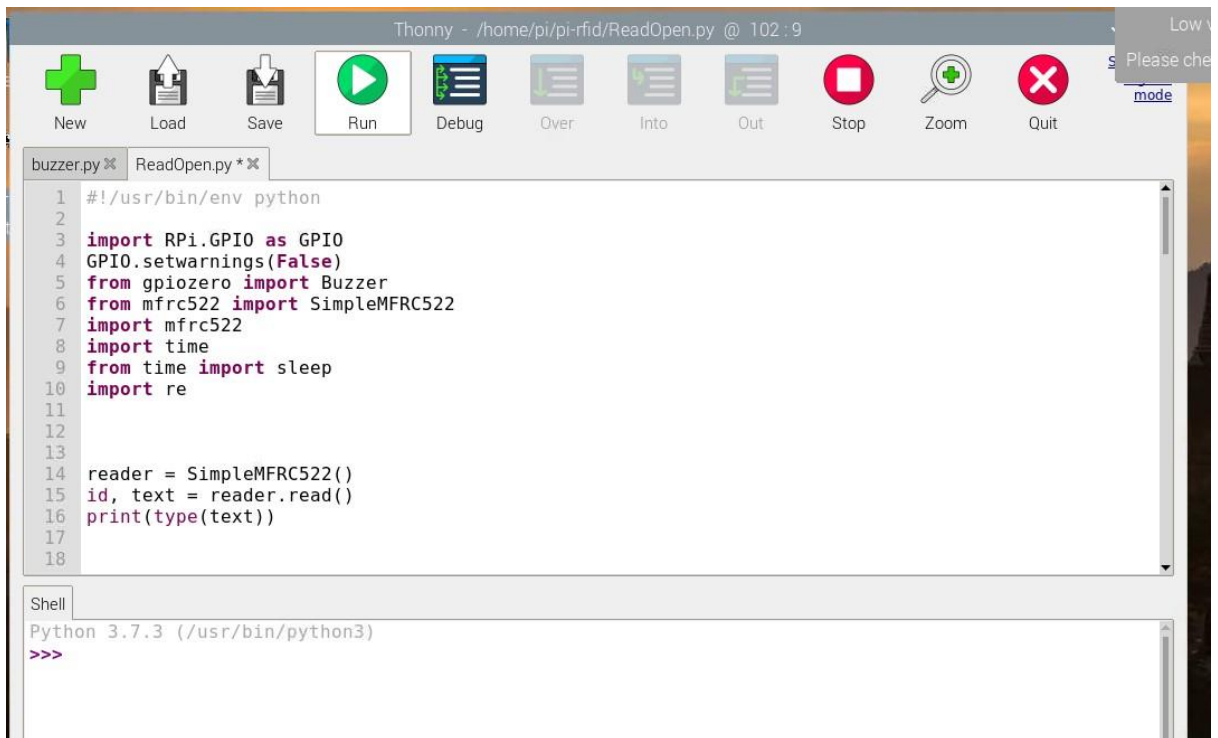

Figure 4.4 Thonny Python Integrated Developer Environment (IDE) code writing

```

#!/usr/bin/env python

import RPi.GPIO as GPIO
GPIO.setwarnings(False)
from gpiozero import Buzzer
from mfrc522 import SimpleMFRC522
import mfrc522
import time
from time import sleep
import re

reader = SimpleMFRC522()
id, text = reader.read()
print(type(text))

def readtag():

    try:
        result = re.findall(f"\d+", text)
        type(result)
        # print("Your Tag UID is: ", result.group(0))
        print(id)
        print("This tag name is: ", text)

    finally:
        GPIO.cleanup()

def opengate():
    GPIO.setmode(GPIO.BOARD)
    GPIO.setup(11, GPIO.OUT)
    p = GPIO.PWM(11, 50)
    p.start(0)
    p.ChangeDutyCycle(7)
    time.sleep(4)

```

Figure 4.5 Python script for gate system



```

    print ("LED off")

    GPIO.output(ledpin,GPIO.LOW)
    GPIO.cleanup()

def buzz():
    GPIO.setmode(GPIO.BCM)
    buzzer = Buzzer(13)

    buzzer.on()
    sleep(1)
    buzzer.off()
    sleep(1)
    GPIO.cleanup()

readtag()

if int(text) == 34567:
    print("This is a valid tag")
    led()
    buzz()
    opengate()
else:
    print("not a valid tag")
    led2()
    buzz()

```

Figure 4.6 Python script for gate system

```

GPIO.output(11, False)
p.ChangeDutyCycle(2)
time.sleep(1)
p.stop()
GPIO.cleanup()

def led():
    ledpin=26
    GPIO.setmode(GPIO.BCM)
    GPIO.setwarnings(False)
    GPIO.setup(ledpin,GPIO.OUT)

    print ("LED on")

    GPIO.output(ledpin,GPIO.HIGH)

    time.sleep(2)

    print ("LED off")

    GPIO.output(ledpin,GPIO.LOW)
    GPIO.cleanup()

def led2():
    ledpin=16
    GPIO.setmode(GPIO.BCM)
    GPIO.setwarnings(False)
    GPIO.setup(ledpin,GPIO.OUT)

    print ("LED on")

    GPIO.output(ledpin,GPIO.HIGH)

    time.sleep(2)

    print ("LED off")

```

Figure 4.7 Python code for gate system

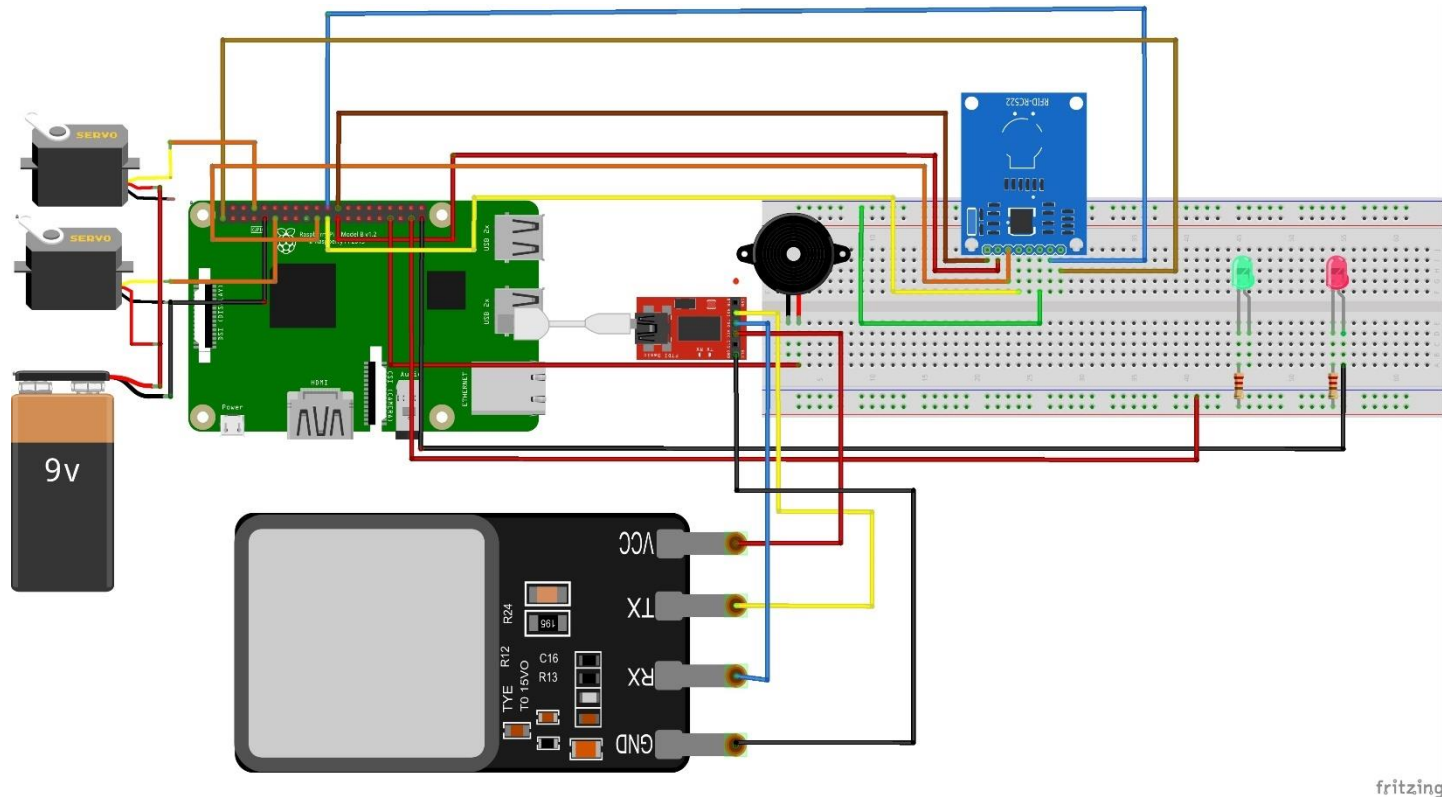

Figure 4.8 Breadboard view of Automated Gate System Using RFID

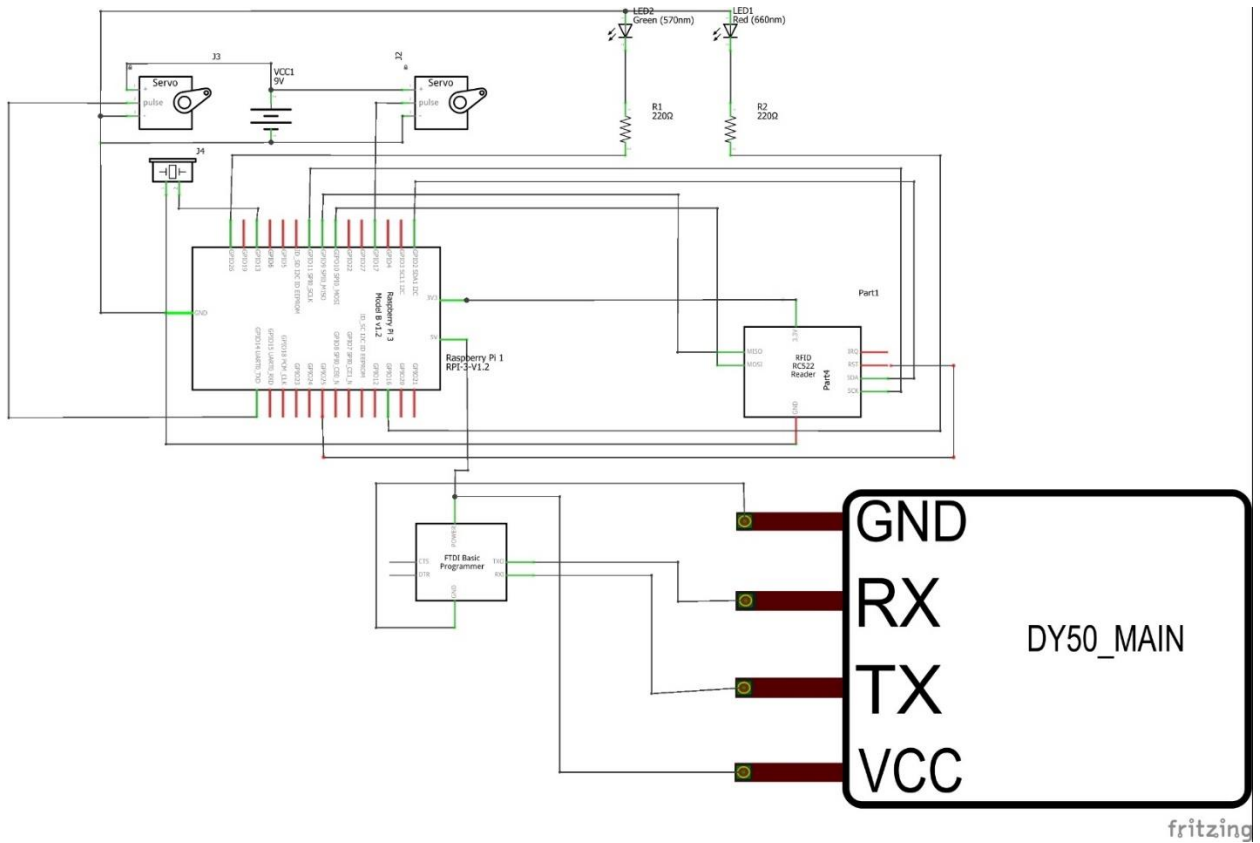

Figure 4.9 Schematic Diagram of Automated Gate System Using RFID

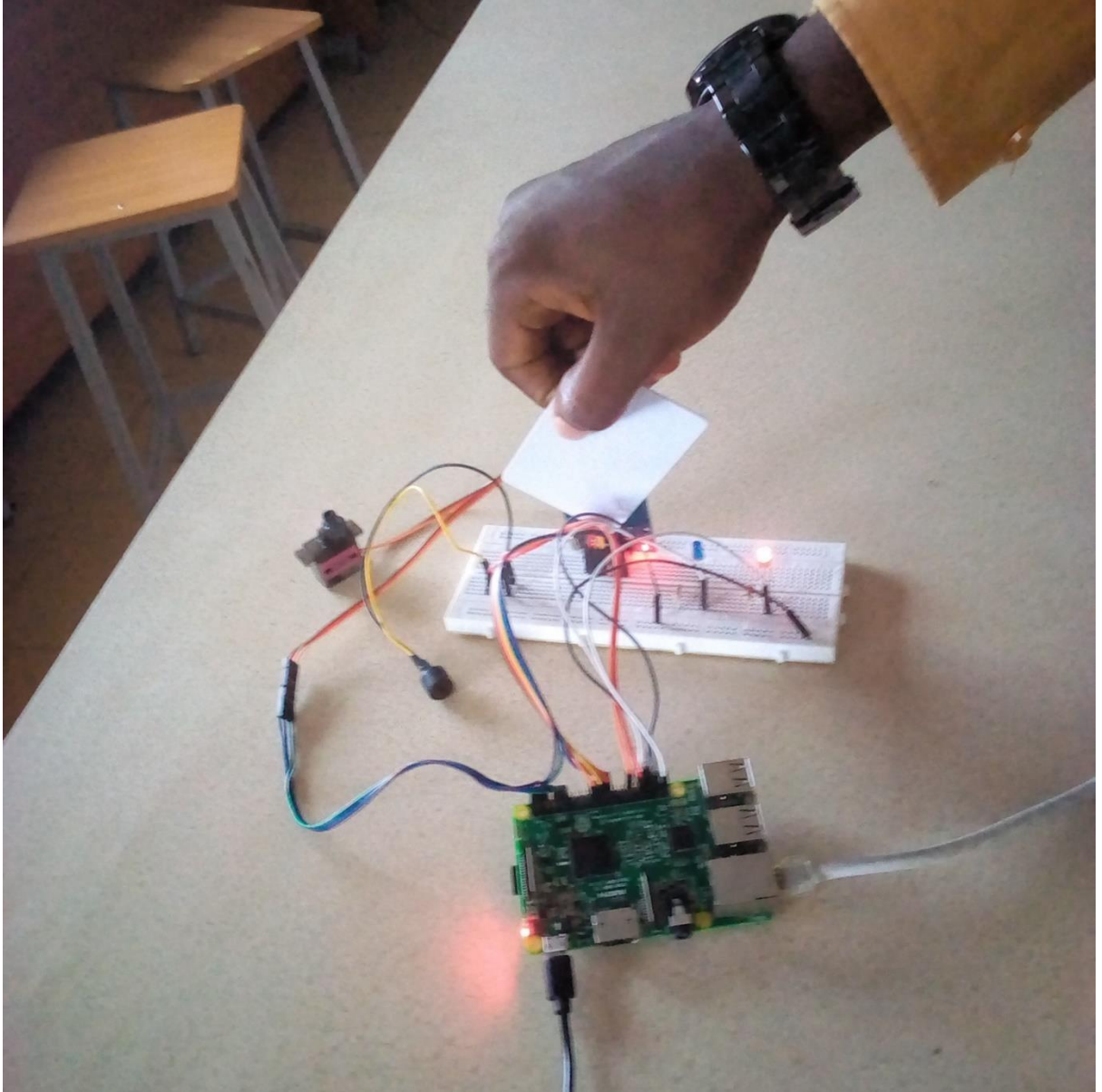
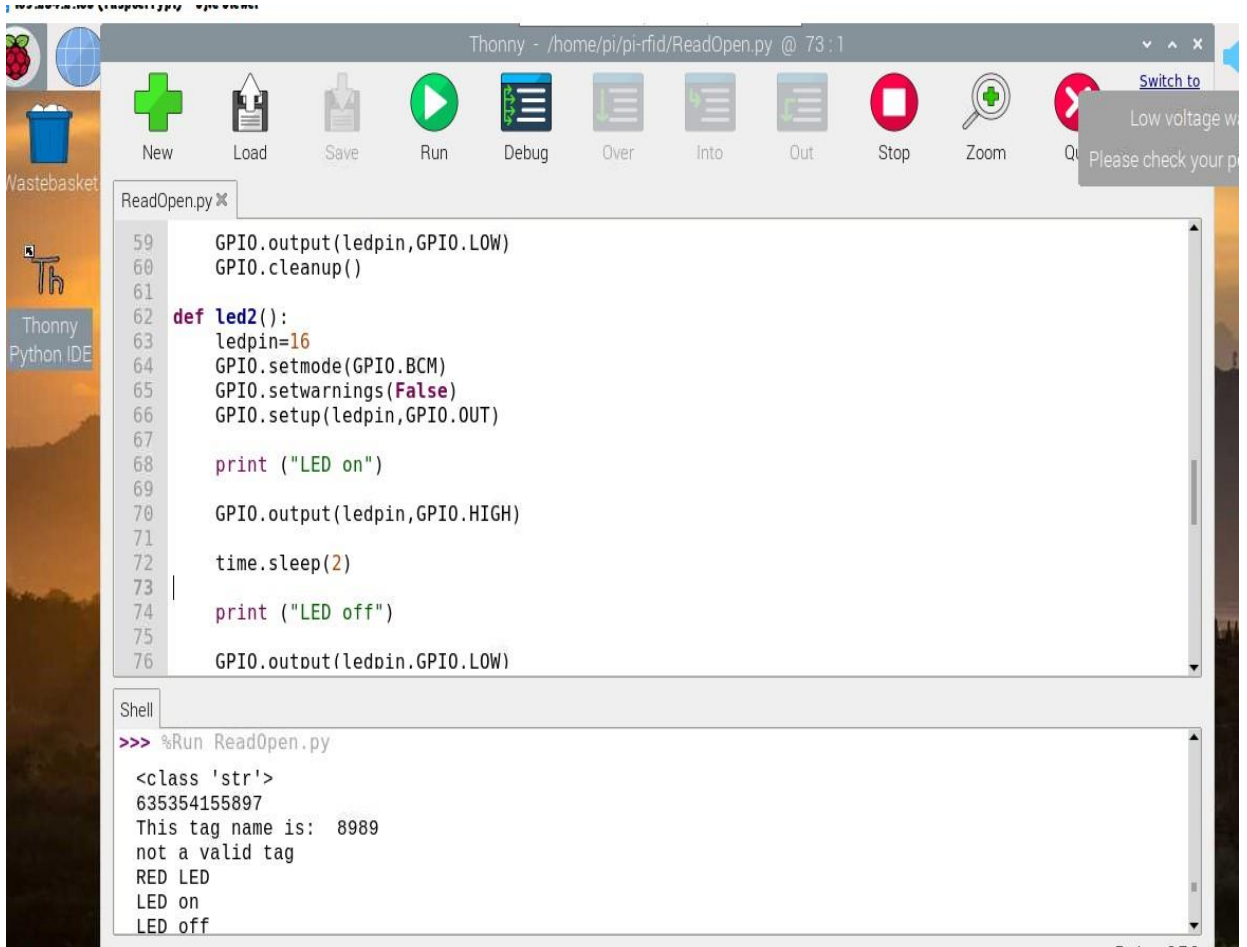

Figure 4.10 Unauthenticated RFID tag being denied access



```
Thonny - /home/pi/pi-rfid/ReadOpen.py @ 73 : 1
New Load Save Run Debug Over Into Out Stop Zoom Q
Low voltage w
Please check your p

ReadOpen.py ✕
59 GPIO.output(ledpin,GPIO.LOW)
60 GPIO.cleanup()
61
62 def led2():
63     ledpin=16
64     GPIO.setmode(GPIO.BCM)
65     GPIO.setwarnings(False)
66     GPIO.setup(ledpin,GPIO.OUT)
67
68     print ("LED on")
69
70     GPIO.output(ledpin,GPIO.HIGH)
71
72     time.sleep(2)
73
74     print ("LED off")
75
76     GPIO.output(ledpin,GPIO.LOW)

Shell
>>> %Run ReadOpen.py
<class 'str'>
635354155897
This tag name is: 8989
not a valid tag
RED LED
LED on
LED off
```

Figure 4.11 Code Result of an invalid RFID tag

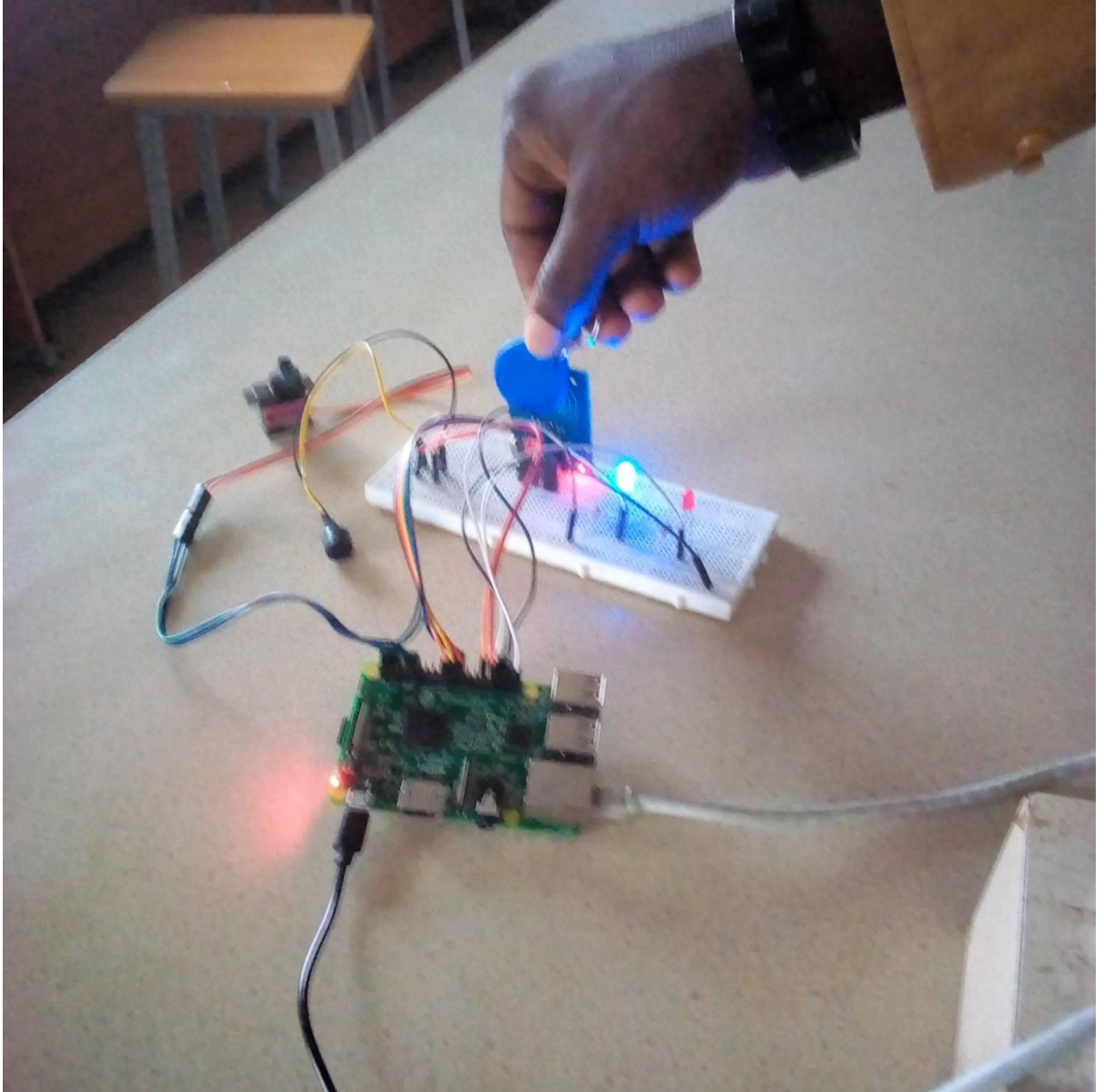

Figure 4.12 Authenticated RFID tag granted access

The image shows a screenshot of the Thonny IDE interface. The title bar reads "Thonny - /home/pi/pi-rfid/ReadOpen.py @ 72:1". The toolbar includes icons for New, Load, Save, Run, Debug, Over, Into, Out, Stop, Zoom, and Quit. A warning message "Low voltage warning Please check your power supply" is visible in the top right corner.

The main editor window displays the following Python code in a file named "ReadOpen.py":

```
59 GPIO.output(ledpin,GPIO.LOW)
60 GPIO.cleanup()
61
62 def led2():
63     ledpin=16
64     GPIO.setmode(GPIO.BCM)
65     GPIO.setwarnings(False)
66     GPIO.setup(ledpin,GPIO.OUT)
67
68     print ("LED on")
69
70     GPIO.output(ledpin,GPIO.HIGH)
71
72     time.sleep(2)
73
74     print ("LED off")
75
76     GPIO.output(ledpin,GPIO.LOW)
```

The Shell window at the bottom shows the output of the code execution:

```
<class 'str'>
1077657150568
This tag name is: 34567
This is a valid tag
GREEN LED
LED on
LED off
```

Figure 4.13 Code result of a valid RFID tag



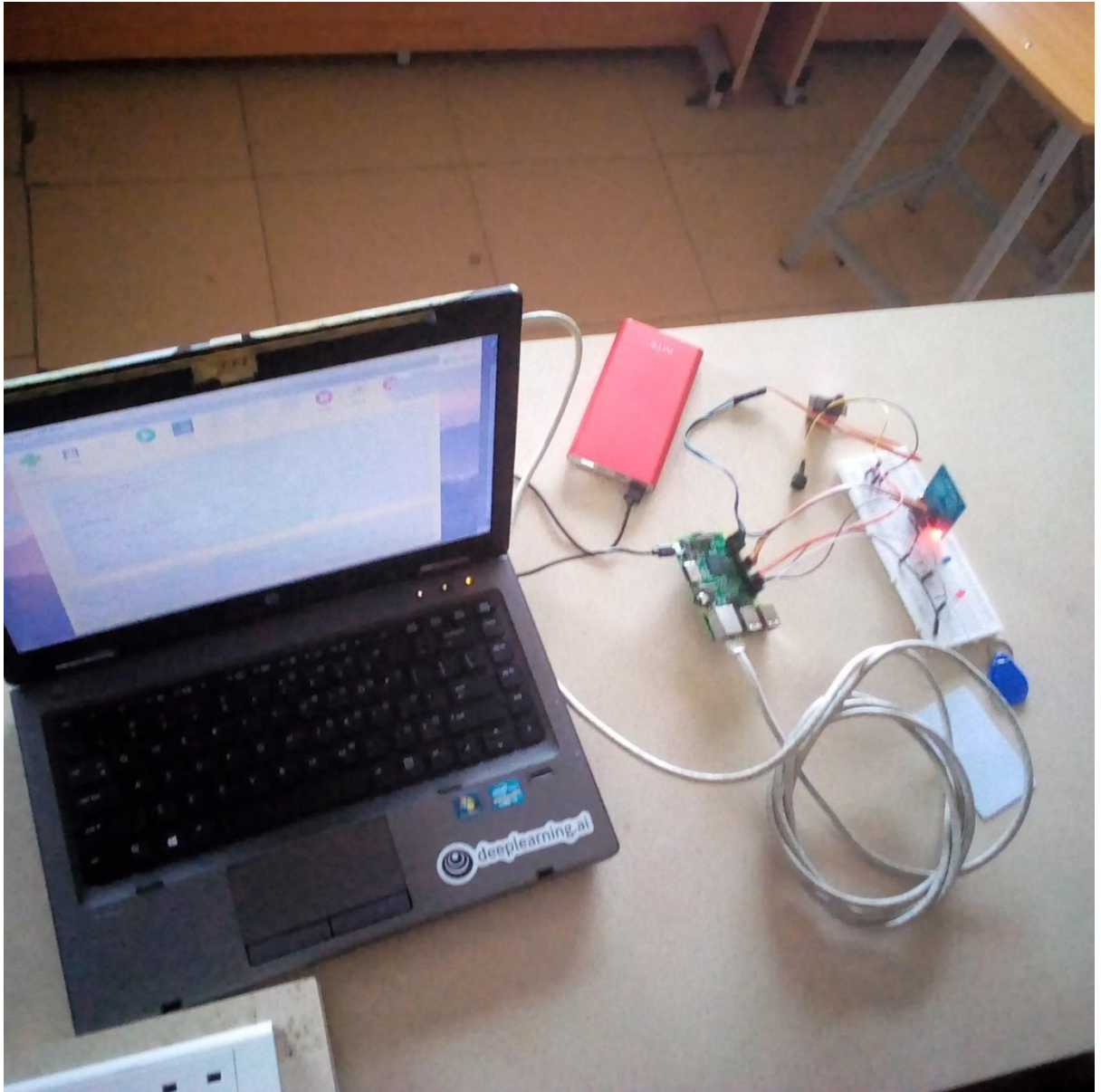

Figure 4.14 Image of full system implementation



Figure 4.15 Image of full system implementation

## **CHAPTER FIVE**

### **CONCLUSION AND RECOMMENDATION**

The predicted outcomes of the research into RFID-based Gate Automation were based on the basic project objectives. Identifying the problem's results. To allocate and register users in the database as well as to generate reports, the admin or manager is responsible.

This investigation demonstrated that the hardware specifications can be properly addressed by the approaches used in this study. It can thus be concluded that with this system in place, the manual process of access control and security is resolved.

Based on the objectives previously mentioned, the study on the topic Gate Automation with RFID returned predicted findings. the discovery of the problem's root This manager or administrator assigns users to the database and generates reports.

This investigation found that the procedures employed here are appropriate for the hardware necessary. With the introduction of this system, it is reasonable to conclude that manual access control and security have been solved.

## **5.1 CONCLUSION**

In conclusion, this study has designed and implemented an automated gate system that solves the challenges of access and student identity management within the hostels. The study was able to identify the various constraints that characterized this process and by this define the system and user requirements. The design of this system was also specified adequately with relevant UML diagrams so suit to the expected functions of the proposed system.

## **5.2 RECOMMENDATION**

Future works in this area be done to integrate into schools, businesses, organisations and all places requiring access to sensitive information.

Additional sources of power for the gate like solar energy can be implemented as a backup supply.

Online database can be created to store more user information and reducing space and increasing redundancy. Also, this system can be merged with machine learning algorithms for vehicle identification via license plate.

## REFERENCES

AI, A. h. (2021). A history of automation: the rise of robots and AI. Retrieved from Think Automation: <https://www.thinkautomation.com/bots-and-ai/a-history-of-automation-the-riseof-robots-and-ai/>

Alexander Goldberg, P. (2020, November 5). The History of RFID. Retrieved from Labtag: <https://blog.labtag.com/the-history-of-rfid/>

Amsler, S. (2021). RFID-radio-frequency-identification. Retrieved from IoT Agenda: <https://internetofthingsagenda.techtarget.com/definition/RFID-radio-frequency-identification>

Axiomtech. (2021). Vehicle Detection System. Retrieved from Axiomtech: <https://www.axiomtek.com/Default.aspx?MenuId=Solutions&FunctionId=SolutionView&ItemId=36&Title=Vehicle+Detection+System>

Brightline IT. (2021). security automation understanding the risks and benefits. Retrieved from BrightlineIT: <https://brightlineit.com/security-automation-understanding-the-risks-andbenefits/>

Chainwire fencing specialist. (2021). Pros and Cons of Automating your Security Gates.

Retrieved from Chainwire fencing specialist:

<https://www.fencingspecialist.com.au/blog/pros-cons-automating-securitygates/#:~:text=Disadvantages%20of%20automatic%20security%20gates&text=First%2C%20>

[0your%20automatic%20security%20gate,second%20disadvantage%20is%20the%20price.](https://www.fencingspecialist.com.au/blog/pros-cons-automating-securitygates/#:~:text=Disadvantages%20of%20automatic%20security%20gates&text=First%2C%20)

CXJ RFID Factory. (2017, September 27). Which RFID Frequency Fits Your Needs ?

Retrieved from CXJ RFID factory: <https://www.cxjrfidfactory.com/which-rfid-frequencyfits-your-needs/>

Elite. (2021). KEYPADS. Retrieved from Elite: <https://elitegates.net/collections/keypads>

Engineers, L. M. (2021, August 1). What is RFID? How It Works? Interface RC522 RFID

Module with Arduino. Retrieved from Last Minute Engineers: <https://lastminuteengineers.com/how-rfid-works-rc522-arduino-tutorial/>

Gated Community News. (2020, October 5). ACCESS CONTROL IN GATED COMMUNITIES: BEST PRACTICES. Retrieved from Gated Community News: <https://gatedcommunitynews.com/access-control-in-gated-communities-best-practices/>

Gillis, A. S. (2020, August). biometrics. Retrieved from searchsecurity.techtarget: <https://searchsecurity.techtarget.com/definition/biometrics>

Groover, M. P. (2020, October 22). Automation. Retrieved from Britannica: <https://www.britannica.com/technology/automation>

Gruber, J. (2020, November 18). Gate Intercom System: How to Choose the Right One in 2021. Retrieved from ButterflyMX: <https://butterflymx.com/blog/gate-intercom-system/>

Heyden, D. (2008, May). RFID Applications. Retrieved from Fibre2Fashion: <https://www.fibre2fashion.com/industry-article/3271/rfid-applications>

Introduction to Automatic Gates. (2021). Retrieved from Silva Consultants: <https://www.silvaconsultants.com/intro-to-automatic-gates>

Ivory Security Limited. (2021). Gate Automation Systems. Retrieved from Ivory Security Limited: <http://www.ivorysecurity.co.uk/gate-automation.html>

Kaufman, M. (2020, July 23). A Brief History of Automation. Retrieved from ExelaTech: [https://www.exelatech.com/in/blog/brief-history-automation?language\\_content\\_entity=en](https://www.exelatech.com/in/blog/brief-history-automation?language_content_entity=en)

Landt, D. J. (2001). Shrouds of Time The history of RFID. AIM Association of the Automatic Identification and Data capture Industry.

Locsin, A. (2021). What Are the Main Purposes of ID Cards? Retrieved from CHRON:  
<https://smallbusiness.chron.com/main-purposes-id-cards-42103.html>

Mandeep Kaur, M. S. (2011). RFID Technology Principles, Advantages, Limitations & Its Applications. International Journal of Computer and Electrical Engineering , Vol.3, No.1, 151-157.

Marian, P. (2021). Double Pole Double Throw DPDT Relay. Retrieved from ElectroSchematics: <https://www.electroschematics.com/dpdt-switch-relay/>

Morelli, B. (2017, March 21). 15 Free eBooks to Learn Python. Retrieved from CodeBurst:  
<https://codeburst.io/15-free-ebooks-to-learn-python-c299943f9f2c>

Peter Darcy, P. P. (2011). The Challenges and Issues Facing the Deployment of RFID Technology. Institute of Integrated and Intelligent Systems, Griffith University.

Raspberry . (2021, August 1). Raspberry Pi 3 Model B. Retrieved from RaspberryPi:  
<https://www.raspberrypi.org/products/raspberry-pi-3-model-b/>

Servo Database. (2021). TowerPro SG90 Servo. Retrieved from Servo Database:  
<https://servodatabase.com/servo/towerpro/sg90>

Technology, R. T. (2021). RFID Tag Technology. Retrieved from AB&R:  
<https://www.abr.com/passive-rfid-tags-vs-active-rfid-tags/>

Techopedia. (2021). Access Management (AM). Retrieved from Techopedia:  
<https://www.techopedia.com/definition/28004/access-management-am>

Thrasher, J. (2013, August 22). How is RFID Used in the Real World. Retrieved from atlasRFIDstore: <https://www.atlasrfidstore.com/rfid-insider/what-is-rfid-used-for-inapplications/>

Want, R. (2006, March). An Introduction to RFID Technology. Retrieved from Computer.org: <https://www.computer.org/csdl/magazine/pc/2006/01/b1025/13rRUxlgxLD>

Xuejun Qian, S. W. (2019). Application of Mechanical Automation Technology in Manufacturing. IOP Conference Series: Materials Science and Engineering (pp. 1-5). IOP.

Yida. (2019, September 25). UART vs I2C vs SPI – Communication Protocols and Uses. Retrieved from Seed Studio: <https://www.seeedstudio.com/blog/2019/09/25/uart-vs-i2c-vsspi-communication-protocols-and-uses/>

Thrasher, J. (2013, August 22). How RFIDs Are Used in the Real World. Retrieved July 16, 2021, from <https://www.atlasrfidstore.com/rfid-insider/what-is-rfid-used-forinapplications/>

Darcy, P., Stantic, B. & Derakhshan, R. (2007). Correcting Stored RFID Data with NonMonotonic Reasoning, Principles and Applications in Information Systems and Technology (PAIST) 1(1): 65–77

Langheinrich, M. (2009). A Survey of RFID Privacy Approaches, Personal Ubiquitous Comput. 13: 413–421.